

Operation Manual

Universal Video Interface Series



IN2000 Analog / TTL / ECL Video Interface

IN2001 Analog / TTL / ECL Video Interface



TABLE OF CONTENTS

Description / Features	1
IN2000 / IN2001 Differences	2
Input Compatibility	2
Output Compatibility.....	3
IN5100 Series Monitor Loop Cables	3
Installation	4
Application Diagram.....	5
Horizontal Position Control	6
RGB Gain Controls.....	6
Blue Enhancement Control	6
Control Location Diagrams.....	7
Internal Controls.....	8
Horizontal Blanking Control.....	9
Dip Switch Settings	9
Factory Default Settings.....	9
Sync on Green Output.....	9
Monochrome Output	9
Disable / Enable Horizontal Position Control.....	10
Enable Blanking Control.....	10
IN2001 Internal Fuses.....	10
IN5100 Series Cables - Partial Listing	11
IN2000 / IN2001 Input Pin Configuration	11
Interfacing to Computers with BNC Outputs	12
Specifications	13
Included Accessories / Optional Accessories	14
Troubleshooting.....	14
Warranty.....	16

DESCRIPTION

The **IN2000** and **IN2001** are universal computer video interfaces designed to work with Analog, TTL, and ECL computer video signals. Like other **INLINE** interfaces, the **IN2000 / IN2001** carry out three primary functions:

Signal Splitting - these interfaces allow for the simultaneous connection and viewing of both the computer's local monitor and a second output device such as a large screen data projector, monitor, or color printer.

Electronic Interfacing - Computer video output signals come in three main varieties: Analog, TTL Digital, and ECL Digital. Several different signal sync formats are used including **RGBS** (composite sync), **RGBHV** (separate horizontal and vertical sync signals), **RGsB** (sync on the Green video signal), and **Monochrome with Composite Sync**. The **IN2000/2001** will accept any of these signal types and formats, outputting the signal in the standard **RGBS** Analog video format.

Physical Interfacing - Computers employ many different types of video output connectors, making it difficult to hook up computers directly to data projection devices. The **IN2000 / IN2001** simplify interfacing, routing, and switching tasks by acting as universal adapters. Through the use of **IN5100 Series** removable monitor loop input cables, the **IN2000 / IN2001** can be attached to virtually any computer and will provide a video output signal on four BNC connectors which can easily be connected to an RGB display device.

KEY CONCEPT

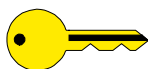

*The **IN2000 / IN2001** are not scan converters. The data projector, monitor, or other output device must be compatible with the horizontal scan rate output by the computer video card.*

The **IN2000 / IN2001** Universal computer video interfaces are fully automatic, offering easy operation and the following features:

- ◆ **100 MHz Bandwidth** - High performance interface design ensures that video signals will be interfaced with no loss of image detail.
- ◆ **Universal Design** - units will operate Analog Video, TTL Digital Video, and ECL Digital Video input. TTL and ECL digital signals are converted to analog video, allowing output signals to be run over long distances on high resolution coaxial cables.
- ◆ **IN5100 Series Monitor Loop Cables** - dozens of specialized input cables are available which allow the **IN2000 / IN2001** to be attached to over 95% of the computers on the market (**IN5100 Series** input cables are not included with the **IN2000 / IN2001**, but are required for operation). This design prevents obsolescence - users may buy the universal interface and **IN5100** cable(s) they need today and add additional cables in the future as their needs change.
- ◆ **Loop-Through Output** - provides a passive output signal for the local computer monitor.
- ◆ **Flexible Output Signal Formats** - **RGBS** (standard), **RGsB**, and **Composite Monochrome**.
- ◆ **Horizontal Position Control** - allows picture to be centered precisely on the data display screen.
- ◆ **RGB Gain Controls** - Red, Green, and Blue levels can be calibrated and output gain boosted to compensate for long cable runs (up to 100' depending on signal horizontal scan frequency).
- ◆ **Blue Enhancement** - improves visibility of digital input signals which contain a lot of blue elements.

IN2000 AND IN2001 DIFFERENCES

These two interfaces are virtually identical in function, features, and operation with only a few minor differences as detailed in the chart below:

	<u>IN2000</u>	<u>IN2001</u>
Power Supply:	External Power Adapter	Internal Power Supply
Size:	1.1" H x 4.8" W x 3.27" D	2" H x 6.75" W x 4.33" D
Adjustment Pots:	Top mounted, hand adjustable	Recessed pots, adjustable with tweaker tool
Dip Switches:	Internal	Externally Accessible

INPUT COMPATIBILITY

The **IN2000 / IN2001** universal interfaces will accept video signals with horizontal scan frequencies between 15.7 KHz and 145.0 KHz. In order to interface to different computers, the appropriate **IN5100 Series** Monitor Loop Cable must be used. For more information and a complete listing of **IN5100** Monitor Loop Cables, see Pages 3 & 11. Common analog, TTL, and ECL signals are listed below along with compatible signal formats.

Analog Video

Common signals (partial listing): VGA, S-VGA, XGA, XGAII, MACII (CX, FX, CI, SI, LC, Quadra, Centris), Sun Sparc Station, Silicon Graphics Iris Indigo.

Compatible Input Signal Formats:

- ◆ RGBS
- ◆ RGBH&V
- ◆ RGsB
- ◆ RsGsBs
- ◆ Monochrome video combined with sync
- ◆ Monochrome with separate composite sync
- ◆ Monochrome with separate H & V syncs

TTL Digital Video

Common signals (partial listing): CGA, EGA, MDA/Hercules, Apple II/III, MAC/MAC+, MAC SE, IBM 3400 Series.

Compatible Input Signal Formats:

- ◆ 1, 2, 3, 4 or 6 bit TTL video with separate composite sync signal
- ◆ 1, 2, 3, 4 or 6 bit TTL video with separate H & V sync signals

ECL Digital Video

Compatible Input Signal Formats:

- ◆ 1 or 3 bit ECL video with separate composite sync
- ◆ 1 or 3 bit ECL video with separate H & V syncs

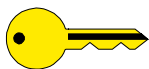
KEY CONCEPT

While the input connector on the **IN2000/2001** looks like a standard 15 pin HD VGA connector (15 pins in three rows), this input uses proprietary pin connections to accommodate the unit's universal design. VGA and other signals can **not** be attached directly to the input without the appropriate **IN5100 Series** loop cable.

OUTPUT COMPATIBILITY

The **IN2000 / IN2001** output an analog video signal in the RGSB format (Red, Green, Blue, and composite sync) on four BNC connectors. The output signal is compatible with many data projectors and monitors. In addition to the default RGSB output format, the **IN2000 / IN2001** may be set to output RGSB or Composite Monochrome Video with Sync by changing the dip switch settings (see Pages 8 & 9).

A special version of the **IN2000** is available for installations requiring an RGBHV output. This unit features a 15 Pin HD Female connector on the output and may be ordered using the following model designation: **IN2000SP RES911722**.

VGA, MACII, and high resolution workstation video cards operate in several different modes encompassing a wide range of resolutions and horizontal scan rates. The **IN2000** and **IN2001** are not scan converters and the data projector or monitor must be compatible with the horizontal scan rate output by the computer video card. Please check the documentation for both the computer video card and the data projection device in order to ensure compatibility.

IN5100 SERIES MONITOR LOOP CABLES

Unlike Dedicated Video Interfaces which are designed to work with one specific type of computer graphic signal and feature a permanently attached input cable, Universal Interfaces such as the **IN2000 / IN2001** function with a wide variety of input signals. These interfaces derive a great deal of their flexibility and "universality" through the use of detachable input cables. The **IN5100 Series** includes dozens of special input cables, each designed for a specific type of computer graphic signal or computer model. For example, the **IN5101A** is designed for VGA / S-VGA / XGA type signals, while the **IN5161A** works with MACII type video signals. Four main characteristics determine the make up of an **IN5100 Series** cable:

- ◆ Analog or Digital signal
- ◆ Sync Format (RGSB, RGBHV, RGSB / RsGsBs, Monochrome)
- ◆ Video Output Connector Type (15 pin HD, 15 pin D, 25 Pin D, etc.) and pin-outs
- ◆ External or Internal Installation

Analog or Digital

Analog Cables are designated with the letter "A" (**IN5101A, IN5133A, IN5161A**). ECL cables also receive the "A" designation (**IN5126A, IN5137A**).

TTL Digital Cables are designated with the letter "T" (**IN5106T, IN5122T, IN5158T**).

External or Internal Cables

Most **IN5100 Series** cables are inserted in-line between the computer's video output and the monitor input cable (see diagram on page 5). Some computers and terminals do not offer an external video output, and INLINE has designed special internal **IN5100 Series** cables for several of these models. Each internally mounted **IN5100 Series** cable includes an instruction sheet describing the installation procedure.

*A partial listing of the most popular **IN5100 Series** Monitor Loop Cables is located on Page 11.*

INSTALLATION

This section offers step-by-step instructions for installing the **IN2000 / IN2001**. A detailed application drawing showing all equipment connections is included on the next page.

1. Turn the computer and computer monitor off. Disconnect the computer monitor (if present) from the video output port on the computer.
2. The **IN5100 Series** cables have a pass-through connector (Male and Female) on one end. The pass-through end is connected to the computer and local monitor. Connect the **male side** of the pass-through connector to the computer's video output port.
3. Connect the local computer monitor (if present) to the **female side** of the **IN51XX** pass-through. If no local monitor is used, a termination plug is required for analog type video signals.

KEY CONCEPT

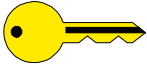

It is very important that the female side of loop-through cables receive a 75 ohm signal termination when interfacing analog video signals. If no termination is provided, the output of the interface will be very overdriven, appearing very bright with poor contrast. The termination is also required by certain video cards (VGA, newer MACII, etc.) because they sense the attached monitor at boot up and set the card for the appropriate mode.

Two of the most popular termination plugs are listed below:

IN5101A Cable Use an **IN9031** 15-pin HD VGA terminator plug (not included).
This emulates a color VGA monitor.

IN5161A Cable Use an **IN9056** 15-pin D MAC II terminator plug (not included).
This emulates a 13"/14" Apple monitor.

4. Connect the other end of the **IN51XX** cable (single male 15 pin HD connector) to the input connector on the **IN2000 / IN2001**.

KEY CONCEPT



*The **IN2000 / IN2001** must be located immediately adjacent to the computer. Do not attempt to lengthen the **IN51XX** loop-through cable. If the **IN51XX** cable is extended, ghosting or other signal problems may occur. Also, the local monitor cable should not be more than 6 - 12' long.*

5. Connect the **IN2000 / IN2001** RGBS output (4 BNC connectors) to the data display device's RGBS input, using four high resolution BNC cables or a multi-conductor RGBS "snake". The **IN7000**, **IN7100**, and **IN7600** series high resolution cables are well suited for this purpose. Take care while making connections to insure that the red output is connected to the red input, green output to the green input, etc.
6. Apply power to the interface. The green power LED will light to indicate the unit is receiving power.
 - IN2000:** Use the 12V 500 mA included power supply.
 - IN2001:** Use a standard power cable (included on U.S. units).
7. Complete the installation by turning the computer and computer monitor on. If required, adjust the horizontal position and RGB gain controls as detailed on Pages 6 and 7.

Application Diagram IN2000 / IN2001

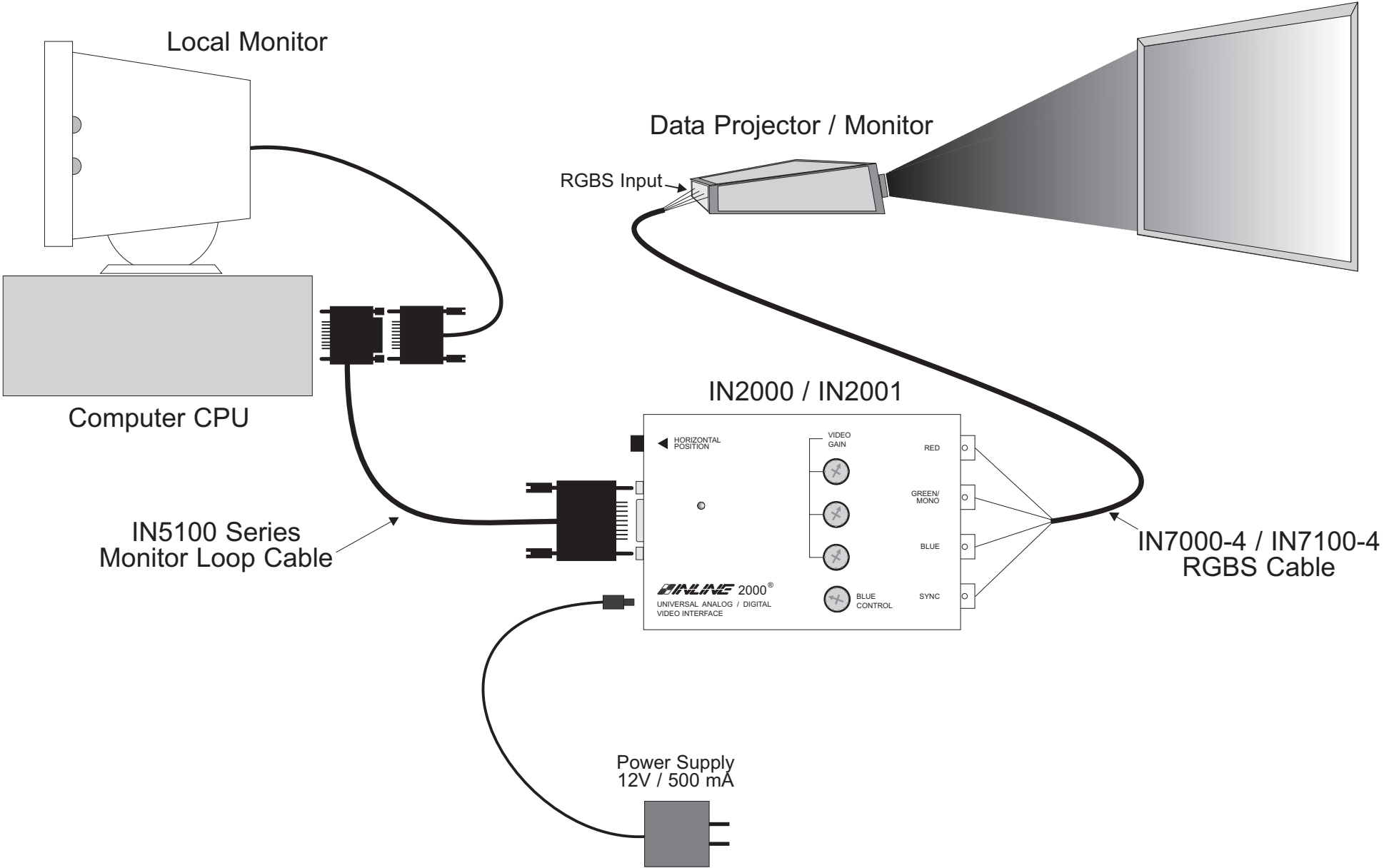

HORIZONTAL POSITION CONTROL

The location of the horizontal position control is diagrammed on the next page. The horizontal position control adjusts the position of the image on the data display device from left to right (it has no effect on the local computer monitor). This control adjusts through a range of 14 full knob rotations, offering very fine control over the image position. The pot emits a soft click if either extreme position is reached.

Many data projectors and monitors have their own horizontal position control, and the interaction of the display device's horizontal control and the interface's horizontal control may result in a dark image on the data display. The following procedure is suggested to ensure best results:

1. Adjust the **IN2000 / IN2001** horizontal position control so a good quality image is displayed. This control should not be set to an extreme position.
2. Adjust the display device horizontal position control until the image is centered as desired.
3. If the image appears dark or the colors are not properly displayed, fine tune the controls on both the display device and the interface until the picture is centered and a good quality image is attained.

RGB GAIN CONTROLS

The RGB gain control locations are shown in the diagrams on the next page. The factory setting is unity gain, meaning that a 1.0 volt Red, Green, or Blue input signal will appear at the **IN2000 / IN2001** outputs as a 1.0 volt signal. These controls may be adjusted if required to calibrate the color balance between the red, green, and blue signals.



Maximum Gain

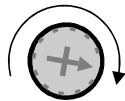

Minimum Gain

The RED, GREEN, and BLUE Gain controls provide a gain adjustment range from 0.8 in the extreme clockwise position to 1.2 in the extreme counterclockwise position. The gain pots may be adjusted by hand or using the small tweaker tool

supplied. *The entire rotation range for the gain pots is just over 180 degrees from stop to stop, so care must be taken not to force or over-rotate the pots.*

BLUE ENHANCEMENT CONTROL (TTL SIGNALS ONLY)

The **IN2000 / IN2001** include a BLUE CONTROL (location shown on the next page) which may be used to enhance the visibility of computer graphic displays containing a lot of blue (blue text, blue graphics, or a blue background). **This control affects only TTL digital input signals** and works by adding various amounts of green into the blue portions of the projected image. This results in an aqua color which is generally more detailed and sharper, especially on older video projectors which often have a fairly soft focus on the blue CRT.

The default for the BLUE CONTROL is no blue enhancement (most accurate color) and corresponds to the control in the extreme counterclockwise position (about 8 o'clock). Full blue enhancement occurs at the extreme clockwise position (about 4 o'clock). The BLUE CONTROL pot may be adjusted by hand or using the small tweaker tool supplied. *The entire rotation range for the BLUE CONTROL is just over 180 degrees from stop to stop, so care must be taken not to force or over-rotate the pot.*

Hori ontal Position Control

IN2000 Top View

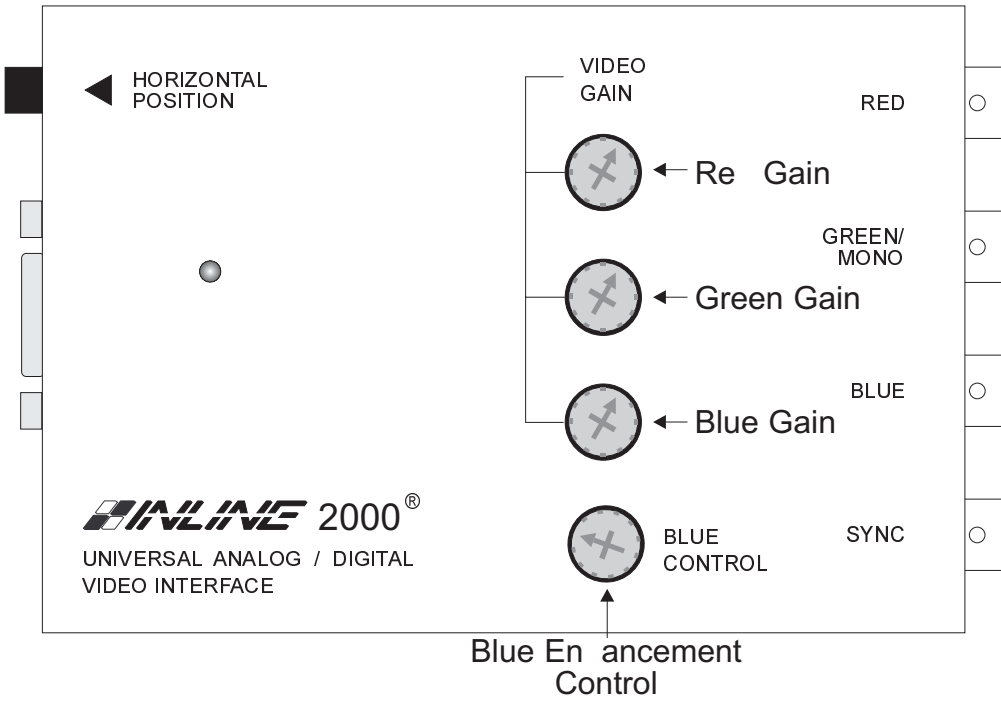

Hori ontal Position Control

IN2001 Top View

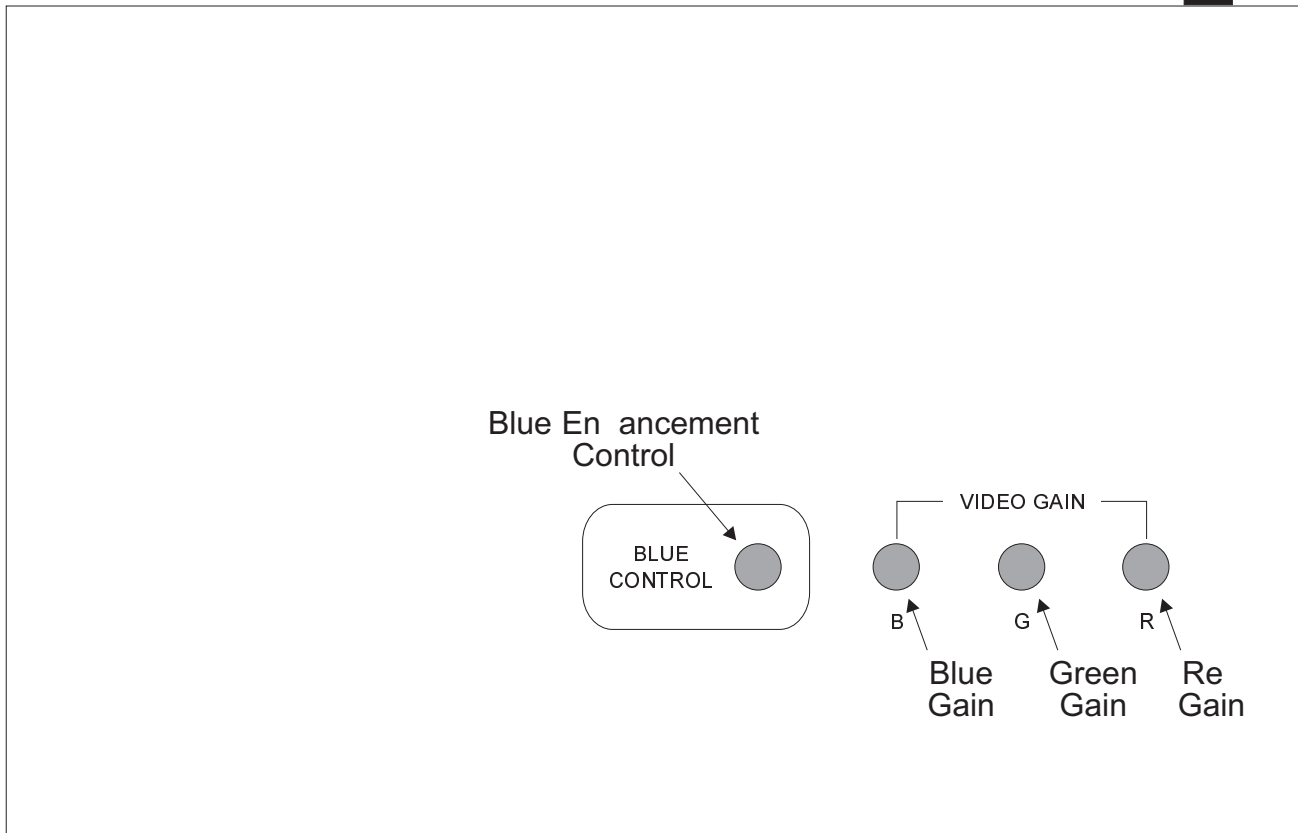

INTERNAL CONTROLS

The **IN2000** and **IN2001** have been designed with several controls which may be used by qualified technicians to adjust specialized signal parameters. These controls, consisting of 10 dip switches and one adjustment pot, are infrequently used and do not require adjustment for normal daily operation. For convenience, the **IN2001** has been designed with two access slots in the bottom of the unit so the case does not need to be opened to change the dip switches and adjustment pot. To access these controls on the **IN2000** follow the procedure listed below.

CAUTION: Any adjustment of internal controls on the **IN2000** must only be carried out by qualified technicians. The interface case must be opened to adjust these controls and extreme care must be taken to avoid static shock to the internal components and/or damage to the pins which connect the top and bottom circuit boards.

The following procedure may be used to access the **IN2000** internal controls.

1. Remove power from the **IN2000**.
2. Remove the screw on the bottom of the unit and lift the top cover off. The top cover must be lifted straight up, remaining absolutely parallel to the bottom half of the interface in order to avoid bending the pins on the pin blocks.
3. Locate the desired dip switches or control pot and gently adjust as required using a small plastic "tweezer" tool. See Pages 9 & 10 for details on these controls.
4. Replace the top cover. The interface end panels fit into slots in the top case and will act as a guide, insuring that the pins and sockets on the top and bottom boards line up properly. Once the two halves have been rejoined, tighten the case screw.

The drawing below diagrams the positions of the dip switches and internal control pot on the **IN2000**.

IN2000 Internal View - Bottom Board

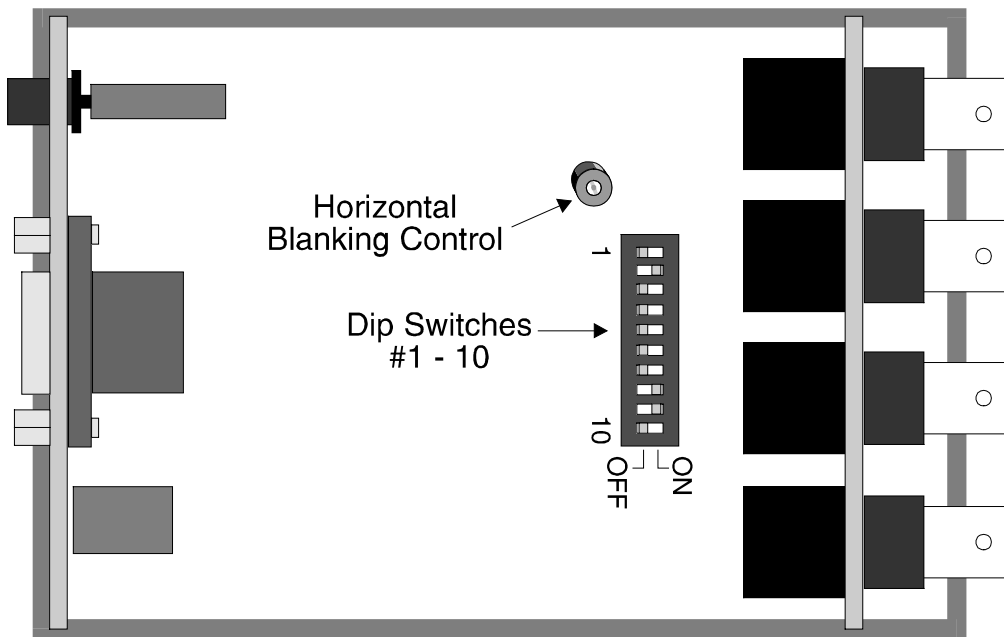

Horizontal Blanking Control (TTL Only)

The Horizontal Blanking Control functions only with TTL digital input signals. This control (location shown on Page 8) will not need to be adjusted on a regular basis. The following image symptoms may indicate that the control is misadjusted: missing background colors, horizontal dark bars across the screen, or missing foreground colors. Before adjusting the Horizontal Blanking Control, first check to make sure that the external Horizontal Position Control (Page 6) is not causing any image problems. The following procedure is recommended for adjusting the Horizontal Blanking Control:

1. **IN2000** - Disconnect power and open the case.
IN2001 - Leave power on during adjustment. Turn unit over to access the dip switches and Horizontal Blanking Control pot located on the bottom of the unit.
2. Activate the Blanking Control Pot by turning Dip Switch #10 to ON.
3. Adjust the control pot until the image quality improves and all the left hand edge of the screen is displayed properly without being cut off.

DIP SWITCH SETTINGS

Most installations will not require any changes to the dip switch settings, and the **IN2000** / **IN2001** will generally be operated with the factory default settings. The Factory Default setting and specialized dip switch settings are indicated below.

Factory Default Settings

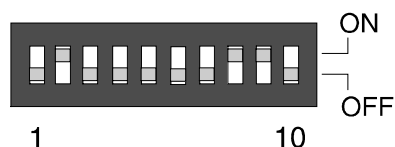

Dip Switches ON: 2, 8 & 9
Signal Format: Red / Green / Blue / Composite Sync
Horizontal Position Control: Active
Blanking Control: Disabled

Sync on Green Output

Turn Dip Switch #1 to ON.

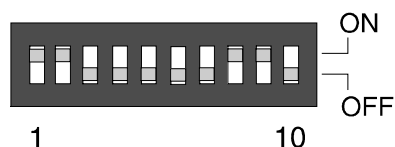

Dip Switches ON: 1, 2, 8 & 9
Signal Format: Red / Green with Composite Sync / Blue

Monochrome Output

Turn Dip Switches #1 and #3 to ON. This combines the red, green, and blue video into composite monochrome. The monochrome signal is output on the GREEN connector.

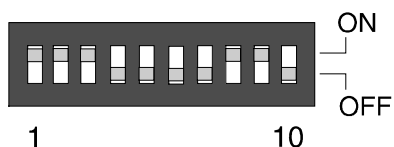

Dip Switches ON: 1, 2, 3, 8 & 9
Signal Format: Composite Monochrome

Disable Horizontal Position Control

Turning Dip Switch #6 to ON disables the Horizontal Position Control. This setting should only be used with Composite Sync or Sync on Green input signals. *If Switch #6 is set to ON when using input signals with separate Horizontal and Vertical syncs, the unit will not output any sync signal, causing the video projector or data monitor attached to the IN2000 / IN2001 output to loose sync and stop displaying an image.*



Enable Blanking Control

Turning on Dip Switch #10 enables the Blanking Control pot. This pot adjusts the video signal left blanking (TTL signals only) to ensure a clamp to black. For more information see Pages 8 & 9.



IN2001 INTERNAL FUSES

The IN2001 contains two internal fuses. If power is applied to the unit and the front LED doesn't light, one of the internal fuses may need to be replaced.

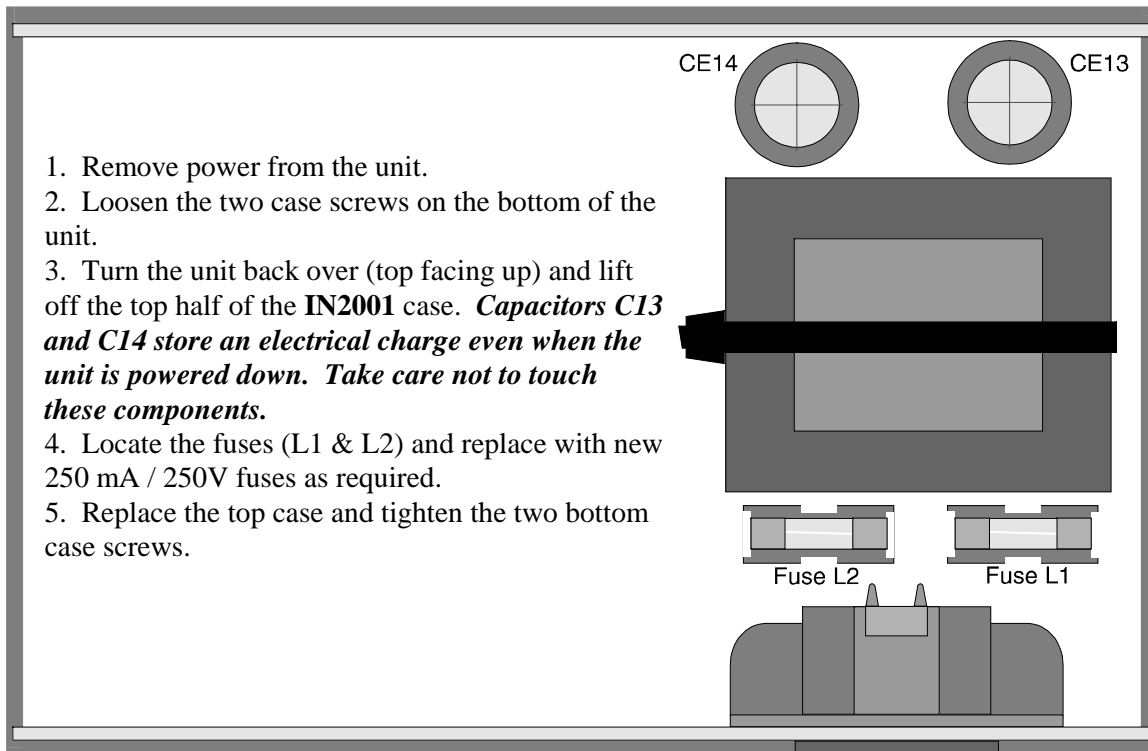

IN5100 SERIES MONITOR LOOP CABLES - PARTIAL LISTING

<u>Computer / Graphics Card</u>	<u>Cable Model</u>	<u>Connector</u>
IBM PC AND COMPATIBLES		
VGA / S-VGA / XGA / XGAII	IN5101A	15 Pin HD
CGA / EGA	IN5106T	9 Pin D
MDA / Hercules	IN5105T	9 Pin D
APPLE		
MACII / Quadra	IN5161A	15 Pin D
MAC / MAC+	IN5107T	Internal Harness
MAC SE	IN5111T	Internal Harness
Apple IIE	IN5122T	9 Pin D
COMMODORE		
Amiga 500 / 1000 / 2000 / 3000 / 4000	IN5147A	23 Pin D
WORKSTATIONS & TERMINALS		
Sun Sparc Station	IN5160A	13W3
Sun Monochrome	IN5126A	9 Pin D
Silicon Graphics Iris Indigo	IN5175A	13W3
NeXT Color	IN5175A	13W3
NeXT Monochrome	IN5137A	19 Pin D
IBM 3192	IN5127A	25 Pin D
NCD 17C	IN5173A	26 Pin HD
DEC VT420 Kit	IN5174A	Internal Harness
1 - BNC - Monochrome	IN5132A	BNC
4 - BNC - RGBS or RGsB	IN5129A	BNC
5 - BNC - RGBHV or RGsB	IN5133A	BNC

IN2000 / IN2001 Input Pin Configuration - 15 Pin HD Female Connector

Pin 1	Red Video	(Analog / TTL determined by Pins 14 & 15)
Pin 2	Green Video	(Analog / TTL determined by Pins 14 & 15)
Pin 3	Blue Video	(Analog / TTL determined by Pins 14 & 15)
Pin 4	Ground	
Pin 5	Ground	
Pin 6	Red Secondary	(TTL only)
Pin 7	Green Secondary	(TTL only)
Pin 8	Blue Secondary	(TTL only)
Pin 9	*Vertical Sync Input	
Pin 10	*Horizontal Sync Input	
Pin 11	Reserved	<i>(Do not connect anything to this Pin!)</i>
Pin 12	Ground	
Pin 13	Invert Video	(TTL Video Signals Only: Ground - Normal, Open - Inverted)
Pin 14	Analog / Digital Select	(Open - Digital, Ground - Analog)
Pin 15	Analog / Digital Select	(Open - Digital, Ground - Analog)

*Short Pins 9 & 10 together for Composite Sync input

INTERFACING TO COMPUTERS WITH BNC OUTPUTS

The **IN5129A**, **IN5132A**, and **IN5133A** are special input cables designed for use with workstations and terminals which have BNC video outputs. The chart below describes the input signal compatibility for each of these cables:

<u>Cable / Description</u>	<u>Monochrome</u>	<u>RGsB</u>	<u>RGBS</u>	<u>RGBH&V</u>
IN5129A 4 - BNCs		X	X	
IN5132A 1 - BNC	X			
IN5133A 5 - BNCs		X		X

Installation Procedure - IN5129A / IN5133A

The video signal input to the **IN2000 / IN2001** must be terminated into 75 ohms for proper image display. In order to achieve this termination the following installation procedure should be followed:

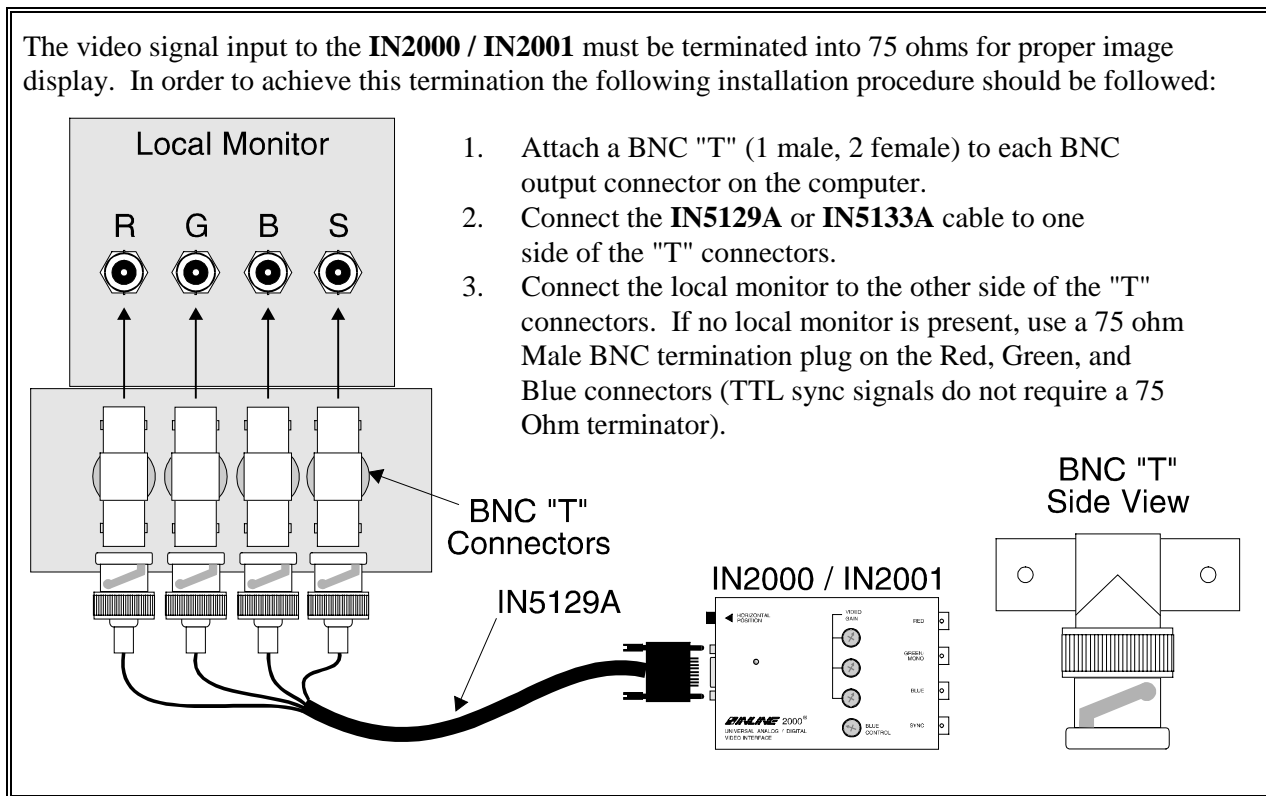

Installation Procedure - IN5132A

The **IN5132A** should be connected directly to the computer's monochrome composite video output. This cable includes an internal 75 ohm termination so the signal should not be split off to a local monitor before feeding it into the **IN5132A** or a double termination will result. If a local monitor is required, use one of the following methods to split the signal:

Looping Method - If the local monitor has a "Loop Out" connector, connect the monitor directly to the computer video output. Turn the Loop Out termination switch to "75 ohm termination OFF" and connect the **IN5132A** to the monitor's Loop Out connector.

Distribution Amplifier - use a high resolution distribution amplifier such as the **IN2055** to split the signal between the local monitor and the **IN5132A / IN2000**.

SPECIFICATIONS

	IN2000 Universal Computer Video Interface	IN2001 Universal Computer Video Interface
Input		
Connector type	15 Pin HD Female - Proprietary Pin-Outs	
RGB Video Signals	Analog / TTL Digital / ECL Digital	
Input Impedance	10 Kilo Ohms	
Maximum Input Voltage	Analog: +- 6V p-p Digital: 5V DC / AC	
Sync Signals	Analog or Digital	
Input Impedance	1 Mega Ohms	
Maximum Input Voltage	+- 6V p-p	
Horizontal Scan Range	15.0 KHz - 145.0 KHz	
Vertical Scan Range	30 Hz - 180 Hz	
Output		
Connector Type	4 BNC Female connectors - Red / Green / Blue / Sync	
Output Signal Formats	RGSB (Default), RGSB, Monochrome and separate sync, Composite Monochrome	
RGB Signals	Analog Video, 75 ohm impedance	
Bandwidth	100 MHz @ -3 dB	
Rise and Fall Times	4.0 nano seconds	
Gain	Adjustable from 0.8 - 1.2	
Sync Signal	Sync output has AGC, 4V p-p unterminated and 2V p-p terminated into 75 ohms	
Horizontal Pulse Width	2.5 μ S @ 15.0 to 36.0 KHz 1.2 μ S @ 37.0 to 145.0 KHz	
Vertical Pulse Width	180 - 200 μ S	
Controls		
External	RGB Gain Blue Enhancement Horizontal Position Control	RGB Gain Blue Enhancement Horizontal Position Control Dip Switches Horizontal Blanking Control
Internal	Dip Switches Horizontal Blanking Control	None
Dimensions		
Size	1.1" H x 4.8" W x 3.27" D	2" H x 6.75" W x 4.33" D
Shipping Weight	3 lb.	4 lb.
Power		
Power Supply	External AC to DC Power Transformer, 12V 500 mA	Internal Transformer - Factory set at 110V or 220V AC
Consumption	3 Watts	3 Watts
Approvals	UL1950, CAN/CSA-22.2 No.950, Third Edition CE: EN55022 (1987), EN50081-1 (1991), EN50082-1 (1992 and 1994), EN0950-92	

Parts and Accessories Included		
	IN2000 Adjustment Tool 12V 500 mA Power Supply Operations Manual	IN2001 Adjustment Tool AC Power Cable (US only) Operations Manual

Optional Accessories	
IN5100 Series Input Cables	See Page 11 for a partial listing of available input cables. For a complete listing of IN5100 Series input cables see the current INLINE Product Catalog.
IN7000 Series RGBS Cable	4 - BNC Cable available in a variety of lengths from 6' to 100'
IN7100 Series RGBS Cable	4 - BNC High Resolution Cable, available in lengths from 6' to 100'
IN7600 Series RGBS Cable	4 - BNC High Resolution Heavy Duty Cable, lengths from 6' to 100'
The RGBS cables above are available in longer lengths by custom order and may also be purchased in bulk quantities along with BNC connectors and crimp tools.	

TROUBLESHOOTING

The display device connected to the IN2000 RGBS output has a bad/scrambled image.

Solution 1: Verify that the correct **IN5100 Series** input cable is being used.

Solution 2: The display device connected to the output of the interface may not be compatible with the computer output. CGA and EGA signals vary from 15.75 to 24 KHz. VGA runs at 31.5 KHz, but SVGA can be as high as 48 - 58 KHz with newer modes such as 1600 x 1200 running at 79 KHz! MACII/Quadra computers sense which monitor is connected and configure themselves accordingly, with horizontal scan rates ranging from 24.48 to 68.9 KHz.

Solution 3: Check the dip switch settings to make sure the unit is putting out a sync format that the display device can use. For most applications the default dip switch settings (see Page 9) will work best.

Solution 4: The RGBS cable may have a bad sync line. Try running the sync through another cable.

The output image is very dark.

Solution: The horizontal position control may be set off to an extreme position or may be interacting poorly with the horizontal position control on the display device. Follow the horizontal position adjustment procedure listed on Page 6.

The output image is missing a color.

Solution: Possibly the RGBS cable is bad. Try switching connections on the output to verify that the bad color's cable is OK (*Example:* If there is no red, try running the green output through the red cable and see if green is displayed or not.)

The output image is very bright and overdriven looking with poor contrast.

Solution 1: The loop through cable is probably being used without a local monitor and the signal is therefore unterminated. Use either a local monitor or a termination plug at the monitor loop-through connector on the **IN5100 Series** cable. If this is not the problem try #2.

Solution 2: Verify the gain settings on the **IN2000 / IN2001** RGB gain pots. If they are set to a very high gain level, reduce the gain as required.

Solution 3: Check the contrast and brightness settings on the display device. Many CRT type display devices look best with the contrast set toward the upper end of the adjustment range (75 - 95%) and the brightness set towards the middle of the adjustment range (40 - 60%).

The output image is ghosting.

Solution: The **IN5100 Series** cables are designed to plug directly into the computer's graphic card and a short (6 to 12 ft) monitor cable attached to the loop through output. An extension cable on the input or a very long monitor cable may cause this problem. Do not attempt to extend the length of the **IN5100 Series** monitor loop cable.

When using the IN2000 and an IN5101A with a VGA signal, the image from the RGSB output is violet with a very low green signal.

Solution: The local monitor may be monochrome. If it is a monochrome monitor, the **IN9030** mono adapter must be used - the output of the **IN2000** will be monochrome.

The output image from the IN2000/2001 has horizontal black bars throughout the image when interfacing to TTL video signals (IN5100 cables ending with "T").

Solution: The Horizontal Blanking Control may need adjustment. First check the Horizontal Position Control to ensure it is not causing the problem. If the problem persists, adjust the Horizontal Blanking Control according to the procedure on Pages 8 & 9.

The output image is too green.

Solution 1: The dip switches may be set for Sync on Green output. Try changing the dip switches to factory default settings (see Page 9) so the unit outputs an RGSB signal.

Solution 2: Some MACII and Quadra computers output an RGSB signal. If an **IN5161A** cable is used with the **IN2000 / IN2001**, the interface does not strip the sync off of the green, and the resulting output signal is actually RGSB. The problem can be solved by disconnecting the composite sync signal from the display device, forcing the display to operate in Sync on Green mode. If the display absolutely must have an RGSB signal, then an **IN5104A** cable should be used. The **IN5104A** will force the **IN2000** to strip the sync off of the green and output a true RGSB signal.

The output image is doubled, with two images displayed side-by-side.

Solution: The display device may not be compatible with the horizontal scan rate of the computer. This problem often occurs when a 31.5 KHz VGA signal is sent into an RGB monitor which is only compatible with signals at 15.75 KHz.

If problems persist, call **INLINE Technical Services** at (800) 882-7117 for further assistance.

WARRANTY

- ◆ INLINE warrants the equipment it manufactures to be free from defects in materials and workmanship.
- ◆ If equipment fails because of such defects and INLINE is notified within two (2) years from the date of shipment, INLINE will, at its option, repair or replace the equipment at its plant, provided that the equipment has not been subjected to mechanical, electrical, or other abuse or modifications.
- ◆ Equipment that fails under conditions other than those covered will be repaired at the current price of parts and labor in effect at the time of repair. Such repairs are warranted for ninety (90) days from the day of re-shipment to the Buyer.
- ◆ **This warranty is in lieu of all other warranties expressed or implied, including without limitation, any implied warranty or merchantability or fitness for any particular purpose, all of which are expressly disclaimed.**

The information in this manual has been carefully checked and is believed to be accurate. However, Inline, Inc. assumes no responsibility for any inaccuracies that may be contained in this manual. In no event will Inline, Inc. be liable for direct, indirect, special, incidental, or consequential damages resulting from any defect or omission in this manual, even if advised of the possibility of such damages. The technical information contained herein regarding IN2000 / IN2001 features and specifications is subject to change without notice.

IBM is a registered trademark of International Business Machines. Apple, MAC, Quadra and Centris, are registered trademarks of Apple Computers, Inc. Iris Indigo is a registered trademark of Silicon Graphics. Sun Sparc Station is a registered trademark of Sun Microsystems, Inc. All other trademarks and registered trademarks are the property of their respective companies.

All Rights Reserved © Copyright 1995-1997

© INLINE, INC. ◆ 22860 SAVI RANCH PARKWAY ◆ YORBA LINDA, CA 92887
 (800) 882-7117 ◆ (714) 921-4100 ◆ FAX (714) 921-4160 ◆ www.inlineinc.com