



A WORLD OF A/V SOLUTIONS



INTERFACES

IN2005HR/IN2015HR/IN2025HR
UNIVERSAL ANALOG / TTL / ECL INTERFACES



**IN2005HR /
IN2015HR / IN2025HR**

OPERATION MANUAL



Installation and Safety Instructions

For Models without a Power Switch:

The socket outlet shall be installed near the equipment and shall be accessible.

For all Models:

No serviceable parts inside the unit. Refer service to a qualified technician.

For Models with Internal or External Fuses:

For continued protection against fire hazard, replace only with same type and rating of fuse.



Instructions d'installation et de sécurité

Pour les modèles sans interrupteur de courant:

La prise de courant d'alimentation sera installé près de l'équipement et sera accessible.

Pour tout les modèles:

Pas de composants à entretenir à l'intérieur. Confiez toute réparation à un technicien qualifié.

Pour les modèles équipés de fusibles internes ou externes:

Afin d'éviter tout danger d'incendie, ne remplacer qu'avec le même type et la même valeur de fusible.



Installations- und Sicherheitshinweise

Für Geräte ohne Netzschalter:

Die Netzsteckdose soll in der Nähe des Gerätes installiert und frei zugänglich sein.

Für alle Geräte:

Keine Wartung innerhalb des Gerätes notwendig. Reparaturen nur durch einen Fachmann!

Für Geräte mit interner oder externer Sicherung:

Für dauernden Schutz gegen Feuergefahr darf die Sicherung nur gegen eine andere gleichen Typs und gleicher Nennleistung ausgetauscht werden.



Instalacion E Instrucciones de Seguridad

Modelos Sin Interruptor:

La conexión debe ser instalada cerca del equipo y debe ser accesible.

Para Todos Los Modelos:

Dentro de la unidad, no hay partes para reparar. Llame un tecnico calificado.

Modelos con Fusibles Internos o Externos:

Para prevenir un incendio, reemplace solo con el mismo tipo de fusible.

CE COMPLIANCE

All products exported to Europe by Inline, Inc. after January 1, 1997 have been tested and found to comply with EU Council Directive 89/336/EEC. These devices conform to the following standards:

EN50081-1 (1991), EN55022 (1987)
EN50082-1 (1992 and 1994), EN60950-92

Shielded interconnect cables must be employed with this equipment to ensure compliance with the pertinent Electromagnetic Interference (EMI) and Electromagnetic Compatibility (EMC) standards governing this device.



FCC COMPLIANCE

This device has been tested and found to comply with the limits for a Class A digital device, pursuant to Part 15 of the FCC rules. These limits are designed to provide against harmful interference when equipment is operated in a commercial environment. This equipment generates, uses and can radiate radio frequency energy and, if not installed and used in accordance with the instruction manual, may cause harmful interference to radio communications. Operation of equipment in a residential area is likely to cause harmful interference, in which case the user will be required to correct the interference at their own expense.

DESCRIPTION

The **IN2005HR / IN2015R / IN2025R** are high performance universal computer video interfaces designed to work with Analog, TTL, and ECL computer video signals. Like other **INLINE** interfaces, the **IN2005HR / IN2015R / IN2025R** carry out three primary functions:

Signal Splitting - these interfaces allow for the simultaneous connection and viewing of both the computer's local monitor and a second output device such as a large screen data projector, monitor, or color printer.

Electronic Interfacing - Computer video output signals come in three main varieties: Analog, TTL Digital, and ECL Digital. Several different signal sync formats are used including **RGBS** (composite sync), **RGBH&V** (separate horizontal and vertical sync signals), **RGsB** (sync on the Green video signal), and Monochrome with Composite Sync. The **IN2005HR / IN2015R / IN2025R** will accept any of these signal types and formats, outputting the signal as analog video.

Physical Interfacing - Computers employ many different types of video output connectors, making it difficult to hook up computers directly to data projection devices. The **IN2005HR / IN2015R / IN2025R** simplify interfacing, routing, and switching tasks by acting as universal adapters. Using removable input cables (**IN5100 Series** monitor loop cables or **IN5180B** Buffered Input Modules), the **IN2005HR / IN2015R / IN2025R** can be attached to virtually any computer and will provide a video output signal on five BNC connectors that can easily be connected to an RGB display device. Output signal format may be set to any of the following formats: **RGBH&V** (default), **RGBS**, **RGsB**, or Composite Monochrome.

*Note: When the **IN2025R** is set for **RGsB** output format, sync on the green video output signal will appear only at output A.*

KEY CONCEPT

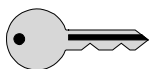

*The **IN2005HR / IN2015R / IN2025R** are not scan converters. The data projector, monitor, or other output device must be compatible with the horizontal scan rate output by the computer video card.*

The **IN2005HR / IN2015R / IN2025R** Universal interfaces offer easy operation and the following features:

- ◆ **230 MHz Bandwidth** - High performance interface design ensures that video signals will be interfaced with no loss of image detail.
- ◆ **Universal Design** - units will operate with Analog Video, TTL Digital Video, and ECL Digital Video input. TTL and ECL digital signals are converted to analog video, allowing output signals to be run over long distances on high resolution coaxial cables.
- ◆ **IN5100 Series Monitor Loop Cables** - dozens of specialized input cables are available, which allow the **IN2005HR / IN2015R / IN2025R** to be attached to over 95% of the computers on the market (**IN5100 Series** input cables are not included with the **IN2005HR / IN2015R / IN2025R**, but are required for operation). This design prevents obsolescence - users may buy the universal interface and **IN5100** cable(s) they need today and add additional cables in the future as their needs change.
- ◆ **Loop-Through Output** - provides a passive output signal for the local computer monitor.
- ◆ **Flexible Output Signal Formats** - **RGBH&V** (standard), **RGBS**, **RGsB**, and Composite Monochrome.
- ◆ **Horizontal Position Control** - allows picture to be centered precisely on the data display screen.
- ◆ **Gain Control** - A single control adjusts the voltage level of the RGB components simultaneously, ensuring that gray scale is maintained. The control may be used to boost output voltage by as much as 30% to compensate for signal loss found in long cable runs.
- ◆ **Sharpness / Peaking Control** - provides high frequency equalization for long cable runs, resulting in a dramatic improvement in image detail and clarity.

IN2005HR / IN2015R / IN2025R DIFFERENCES

These two interfaces are virtually identical in function, features, and operation with only a few minor differences as detailed in the chart below:

	IN2005HR	IN2025R	IN2015R
Power Supply:	External Power Adapter 15 VDC, 600 mA	Internal Universal Power Supply 90 - 260 VAC, 47 - 63 Hz	Internal Universal Power Supply 90 - 260 VAC, 47 - 63 Hz
Output(s):	1 Set of Five BNC Connectors	2 Sets of Five BNC Connectors	1 Set of Five BNC Connectors
Size:	1.1" H x 5.2" W x 4" D	1.65" H x 8.5" W x 6.4" D	1.65" H x 8.5" W x 6.4" D

INPUT COMPATIBILITY

The **IN2005HR / IN2015R / IN2025R** universal interfaces will accept video signals with horizontal scan frequencies between 15.7 kHz and 135 kHz. In order to interface to different computers, the appropriate **IN5100 Series** Monitor Loop Cable must be used. For more information and a complete listing of **IN5100** Monitor Loop Cables, see Pages 3 & 13. Common analog, TTL, and ECL signals are listed below along with compatible signal formats.

Analog Video

Common signals (partial listing):

VGA, S-VGA, XGA, XGAI, MACII (CX, FX, CI, SI, LC, Quadra), PowerMac Sun Sparc Station, Silicon Graphics Iris Indigo.

Compatible Input Signal Formats:

- ◆ RGBS
- ◆ RGBH&V
- ◆ RGsB
- ◆ RsGsBs
- ◆ Monochrome video combined with sync
- ◆ Monochrome with separate composite sync
- ◆ Monochrome with separate H & V sync signals

TTL Digital Video

Common signals (partial listing):

CGA, EGA, MDA/Hercules, Apple II/III, MAC/MAC+, MAC SE, IBM 3400 Series.

Compatible Input Signal Formats:

- ◆ 1, 2, 3, 4 or 6 bit TTL video with separate composite sync signal
- ◆ 1, 2, 3, 4 or 6 bit TTL video with separate H & V sync signals

ECL Digital Video

Compatible Input Signal Formats:

- ◆ 1 or 3 bit ECL video with separate composite sync
- ◆ 1 or 3 bit ECL video with separate H & V sync

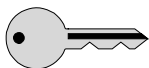
KEY CONCEPT

While the input connector on the **IN2005HR/2025R/2015R** looks like a standard 15 pin HD VGA connector (15 pins in three rows), this input uses proprietary pin connections to accommodate the unit's universal design. VGA and other signals can **not** be attached directly to the input without the appropriate **IN5100 Series** loop cable.

OUTPUT COMPATIBILITY

The **IN2005HR / IN2015R / IN2025R** output an analog video signal in the RGBH&V format (Red, Green, Blue, Horizontal Sync and Vertical Sync) on five BNC connectors. The output signal is compatible with many data grade projectors and monitors. In addition to the default RGBH&V output format, the **IN2005HR / IN2015R / IN2025R** may be set to output RGSB, RGSB or Composite Monochrome Video with Sync by changing the DIP switch settings (see page 9).

VGA, MACII, and high resolution workstation video cards operate in several different modes encompassing a wide range of resolutions and horizontal scan rates. The **IN2005HR / IN2015R / IN2025R** are not scan converters and the data projector or monitor must be compatible with the horizontal scan rate output by the computer video card. Please check the documentation for both the computer video card and the data projection device in order to ensure compatibility.

IN5100 SERIES MONITOR LOOP CABLES

Unlike Dedicated Video Interfaces that are designed to work with one specific type of computer graphic signal and feature a permanently attached input cable, Universal Interfaces such as the **IN2005HR / IN2015R / IN2025R** function with a wide variety of input signals. These interfaces derive a great deal of their flexibility and "universality" through the use of detachable input cables. The **IN5100 Series** includes dozens of special input cables, each designed for a specific type of computer graphic signal or computer model. For example, the **IN5101A** is designed for VGA / S-VGA / XGA type signals, while the **IN5161A** works with MACII type video signals. Four main characteristics determine the make up of an **IN5100 Series** cable:

- ◆ Analog or Digital signal
- ◆ Sync Format (RGSB, RGBH&V, RGSB / RsGsBs, Monochrome)
- ◆ Video Output Connector Type (15 pin HD, 15 pin D, 13W3, etc.) and pin-outs
- ◆ External or Internal Installation

Analog or Digital

Analog Cables are designated with the letter "A" (**IN5101A, IN5133A, IN5161A**). ECL cables also receive the "A" designation (**IN5126A, IN5137A**).

TTL Digital Cables are designated with the letter "T" (**IN5106T, IN5122T, IN5158T**).

External or Internal Cables

Most **IN5100 Series** cables are inserted in-line between the computer's video output and the monitor input cable (see diagram on page 6). Some computers and terminals do not offer an external video output, and INLINE has designed special internal **IN5100 Series** cables for several of these models. Each internally mounted **IN5100 Series** cable includes an instruction sheet describing the installation procedure.

*A partial listing of the most popular **IN5100 Series** Monitor Loop Cables is located on Page 13.*

BUFFERED INPUT MODULES

The **IN5180B Series** is a group of buffered input modules for the **IN2000, IN2001, IN2005HR, IN2025R, and IN2015R** universal interfaces. Buffered input modules may be used in place of the **IN5100 Series** loop input cables and are recommended for applications where the interface will be connected to a workstation running at very high resolution and high scan rates. High quality amplification circuitry provides buffer module bandwidth of 400 MHz or more. The **IN5180B Series** buffered input modules do not require external power as they receive power from the attached interface through the input cable.

The **IN5180B Series** buffered input modules feature high resolution coaxial input and output cables for maximum performance. A 2-foot long input cable connects to the computer video port. A 6-foot long output cable connects to the interface input. The long output cable provides installation flexibility since the buffer module may be placed near the computer while the interface is mounted inside a podium or equipment cabinet. The input cable and local monitor output may be extended if necessary using high resolution coaxial extension cables.

Note that **IN5100 Series** input loop cables may not be lengthened as this may cause reflections in the local monitor and/or the data display device. The **IN5180B** buffered input modules are recommended for any installations where the input cable must be lengthy.

IN5180B Series Buffered Input Modules.

Model	Description
IN5181B	VGA Buffered Input Module
IN5182B	MAC Buffered Input Module
IN5183B	13W3 Buffered Input Module for SUN / SGI Workstations
IN5184B	5-BNC Buffered Input Module

INSTALLATION

This section offers step-by-step instructions for installing the **IN2005HR / IN2015R / IN2025R**. A detailed application drawing showing all equipment connections is included on the next page.

1. Turn the computer and computer monitor off. Disconnect the computer monitor (if present) from the video output port on the computer.
2. The **IN5100 Series** cables have a pass-through connector (Male and Female) on one end. The pass-through end is connected to the computer and local monitor. Connect the **male side** of the pass-through connector to the computer's video output port.
3. Connect the local computer monitor (if present) to the **female side** of the **IN51XX** pass-through. If no local monitor is used, a termination plug is required for analog type video signals.

KEY CONCEPT

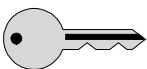

It is very important that the female side of loop-through cables receive a 75 ohm signal termination when interfacing analog video signals. If no termination is provided, the output of the interface will be very overdriven, appearing very bright with poor contrast. Sense Pin termination is also required by certain video cards because they sense the attached monitor at boot up and set the card for the appropriate mode.

4. Connect the other end of the **IN51XX** cable or **IN5180B** Buffered input module (single male 15 pin HD connector) to the input connector on the **IN2005HR / IN2015R / IN2025R**.

KEY CONCEPT

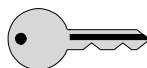

*The **IN2005HR / IN2015R / IN2025R** must be located immediately adjacent to the computer when using an **IN51XX** loop cable. Do not attempt to lengthen the **IN51XX** loop-through cable. If the **IN51XX** cable is extended, ghosting or other signal problems may occur. Also, the local monitor cable should not be more than 6 - 12' long.*

5. Connect the **IN2005HR / IN2015R / IN2025R** output (5 BNC connectors) to the data display device's RGB input, using three, four, or five high resolution BNC cables or a multi-conductor RGBH&V, RGBS, or RGB "snake". The **IN7000 Series**, **IN7100 Series** and **IN7200 Series** high resolution cables are well suited for this purpose. Take care while making connections to ensure that the red output is connected to the red input, green output to the green input, etc.

KEY CONCEPT

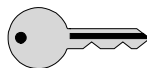

*Since the **IN2025R** has two sets of output BNC connectors, it can drive two data displays simultaneously. The dual output capability is only compatible with RGBHV and RGBS output signal formats. The **IN2025R** will not drive output B when the unit is set for **RGsB** output.*

6. The **IN2005HR / IN2015R / IN2025R** factory default output format is RGBHV. If your display device, routing system, or cabling require a different format, use the DIP switches located on the bottom of the unit to change the output signal to RGBS, RGsB, or Composite Monochrome as desired (see page 9).
7. Apply power to the interface. The green power LED will light to indicate the unit is receiving power.
 - IN2005HR:** Use the 15V 600 mA power transformer (included).
 - IN2025R / IN2015R:** The units adjust automatically to line conditions worldwide from 90 - 260VAC and 43 - 63 Hz. Use the IEC power cord supplied or another A/C cord as appropriate for local A/C wall socket connection.
8. Complete the installation by turning the computer and computer monitor on. If required, adjust the horizontal position, gain, and peaking controls as detailed on Pages 7 and 8.

Application Diagram IN2005HR / IN2015R / IN2025R

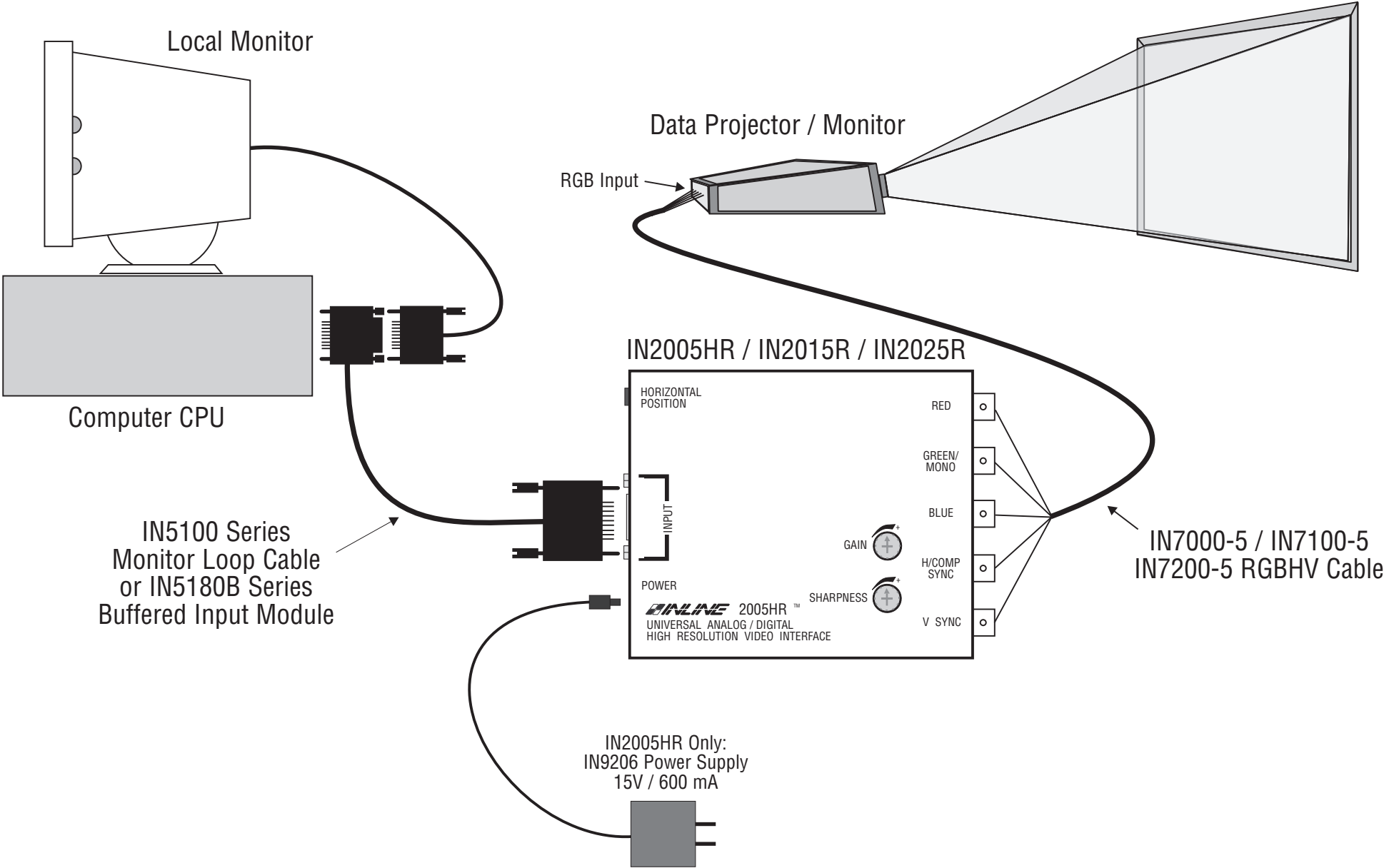

HORIZONTAL POSITION CONTROL

The location of the horizontal position control is diagrammed on the next page. The horizontal position control adjusts the position of the image on the data display device from left to right (it has no effect on the local computer monitor). This control adjusts through a range of 14 full knob rotations, offering very fine control over the image position. The pot emits a soft click if either extreme position is reached.

Many data projectors and monitors have their own horizontal position control, and the interaction of the display device's horizontal control and the interface's horizontal control may result in a dark image on the data display. The following procedure is suggested to ensure best results:

1. Adjust the **IN2005HR / IN2015R / IN2025R** horizontal position control so a good quality image is displayed. This control should not be set to an extreme position.
2. Adjust the display device horizontal position control until the image is centered as desired.
3. If the image appears dark or the colors are not properly displayed, fine tune the controls on both the display device and the interface until the picture is centered and a good quality image is attained.

GAIN CONTROL

The **IN2005HR / IN2015R / IN2025R** offer a unified Video gain control (see illustrations on page 8). This single pot adjusts the video gain of the Red, Green, and Blue signals simultaneously, ensuring that gray scale is not altered. The factory setting is unity gain, meaning that a 0.7 volt Red, Green, or Blue input signal will appear at the **IN2005HR / IN2015R / IN2025R** outputs as a 0.7 volt signal. The gain control may be adjusted as required to calibrate the output signal level as appropriate for the various lengths of coaxial cables and to achieve the best image on the display device.

IN2005HR Only: The Gain control provides a gain adjustment range from 0.0 (no video signal) in the extreme counterclockwise position to 1.3 (30% signal increase) in the extreme clockwise position.

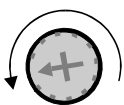

Maximum Gain



Minimum Gain

IN2015R / IN2025R: The Gain control provides a gain adjustment range from 0.7 (30% decrease) in the extreme clockwise position to 1.3 (30% signal increase) in the extreme counterclockwise position.

The gain pot on all models may be adjusted by hand or using the small tweaker tool supplied. ***The entire rotation range for the gain pots is just over 180 degrees from stop to stop, so care must be taken not to force or over-rotate the pots.***

PEAKING / SHARPNESS CONTROL

This control may be used to enhance the visibility of fine details by increasing the sharpness of the displayed image. The factory default setting is minimum (no sharpness enhancement).

IN2005HR - Top Controls

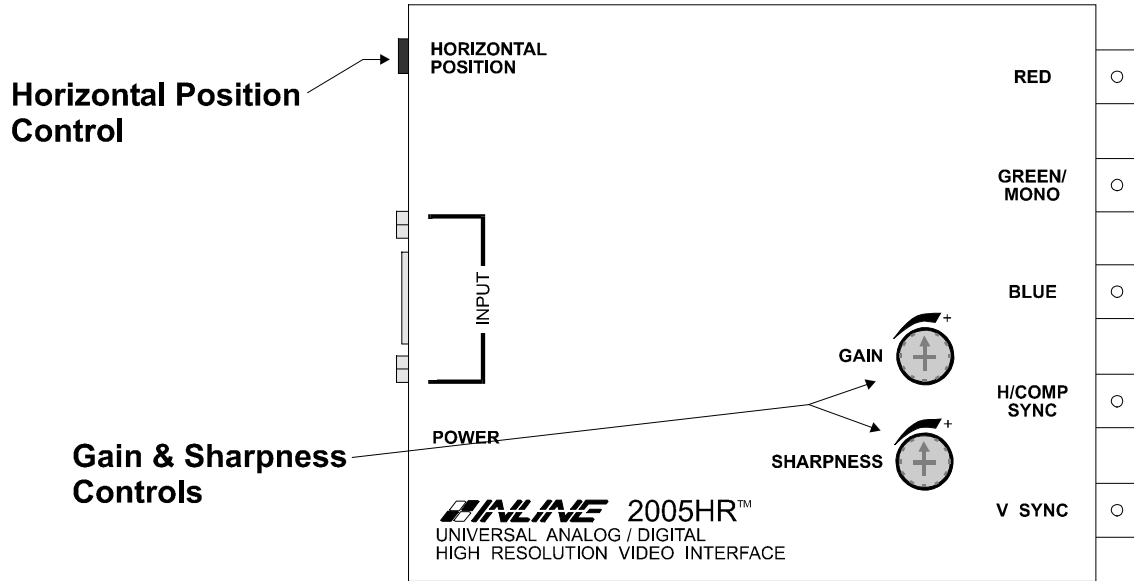

IN2025R - Back Panel

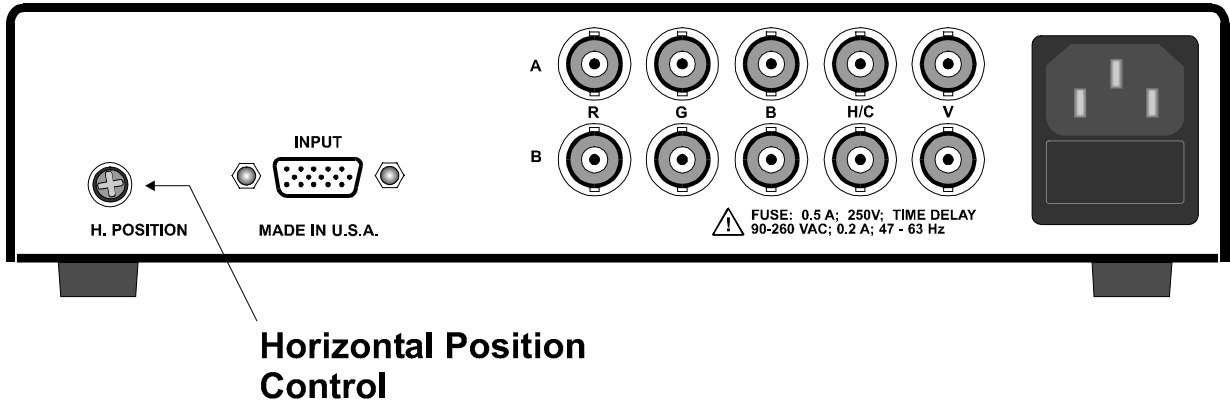

IN2025R Top Controls

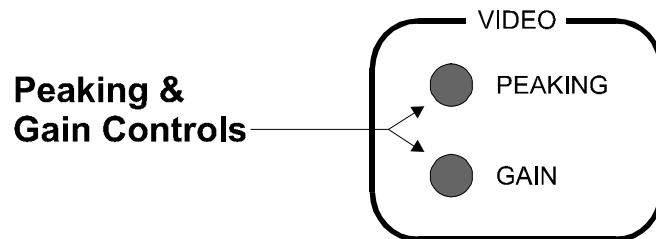

DIP SWITCH SETTINGS

The **IN2005HR / IN2015R / IN2025R** dip switches are located on the bottom of the units. Most installations will not require any changes to the DIP switch settings, and the **IN2005HR / IN2015R / IN2025R** will generally be operated with the factory default settings. The Factory Default setting and specialized DIP switch settings are indicated below.

Factory Default Settings (RGBH&V)

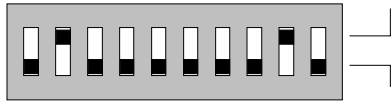

DIP Switches ON: 2 & 9
Signal Format: Red / Green / Blue / H / V
Horizontal Position Control: Active
Blanking Control: Disabled

Sync on Green Output (RGsB)

Turn DIP Switch #1 to ON.



DIP Switches ON: 1, 2, & 9 (#8 in either position)
Signal Format: Red / Green w/Comp. Sync / Blue
Horizontal Position Control: Active
Blanking Control: Disabled

Red, Green, Blue, Sync Output (RGSB)

Turn DIP Switch #8 ON.



DIP Switches ON: 2, 8 & 9
Signal Format: Red / Green / Blue / Composite Sync
Horizontal Position Control: Active
Blanking Control: Disabled

Monochrome Output

Turn DIP Switches #1 and #3 to ON. This combines the red, green, and blue video into composite monochrome. The monochrome signal is output on the GREEN connector.

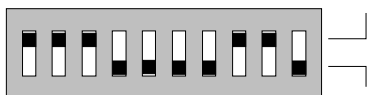

DIP Switches ON: 1, 2, 3 & 9
Signal Format: Composite Monochrome
Horizontal Position Control: Active

Disable Horizontal Position Control

Turning **DIP Switch #6** to ON disables the Horizontal Position Control.



DIP Switches ON: 2, 6, & 9

Enable Blanking Control

Turning on **DIP Switch #10** enables the Blanking Control pot. This pot adjusts the video signal left blanking (TTL signals only) to ensure a clamp to black. For more information see Pages 10 & 11.



DIP Switches ON: 2, 9 & 10

INTERNAL CONTROLS

The **IN2005HR / IN2015R / IN2025R** have been designed with 4 pots that can be used by qualified technicians to adjust specialized signal parameters. These controls, consisting of four adjustment pots, do not require adjustment for normal day-to-day operation. To access the internal adjustments on the **IN2005HR / IN2015R / IN2025R** follow the procedure listed below.

CAUTION: *Any adjustment of internal controls on the IN2005HR / IN2015R / IN2025R must only be carried out by qualified technicians. The interface case must be opened to adjust these controls and extreme care must be taken to avoid static shock to the internal components and/or damage to the pins, which connect the top and bottom circuit boards.*

CAUTION: *Some of the internal transistors are thermally (not mechanically) bonded to the top cover of the unit with heatsink compound. Be sure the heatsink compound is still intact when replacing cover to avoid transistor failure.*

HORIZONTAL BLANKING CONTROL (TTL VIDEO ONLY)

The Horizontal Blanking Control functions only with TTL digital video input signals. This internal control will not need to be adjusted on a regular basis. The following image symptoms may indicate that the control is misadjusted: missing background colors, horizontal dark bars across the screen, or missing foreground colors. Before adjusting the Horizontal Blanking Control, first check to make sure that the external Horizontal Position Control (Page 7) is not causing any image problems. The following procedure is recommended for adjusting the Horizontal Blanking Control.

1. Position the **IN2005HR / IN2015R / IN2025R** to gain access to the bottom of the unit.
2. **IN2005HR Only:** Remove the No.4 Phillips head screw from the bottom of the unit and lift the top cover off. The top cover must be lifted straight up, remaining absolutely parallel to the bottom half of the interface.
IN2015R / IN2025R Only: Remove all of the No.4 Phillips head screws from the sides of the unit and lift the top cover off.
3. Gently lift the top (smaller) circuit board straight up, remaining absolutely parallel to the bottom half of the interface to avoid bending the pins on the pin blocks
4. Note the location of the pot adjustment (page 11). Adjust the pot 1/8 turn clockwise or counterclockwise (depending on image quality) using a small plastic adjustment tool.
5. Reinstall top (smaller) circuit board, making sure that the pins and sockets of the top and bottom boards line up properly.
6. Reinstall the top cover. The interface end panels fit into slots in the top cover and act as a guide.
7. Apply power and observe that image quality improves and that all the left hand edge of the screen is displayed properly without being cut off..
8. Repeat steps 3 thru 7 until the image is proper.
9. Reinstall and tighten the case screw(s).

The drawings below show the positions of the internal control pots of the **IN2005HR**. The circuit board layout is similar for the **IN2025R / IN2015R**.

IN2005HR Internal View- Bottom Board

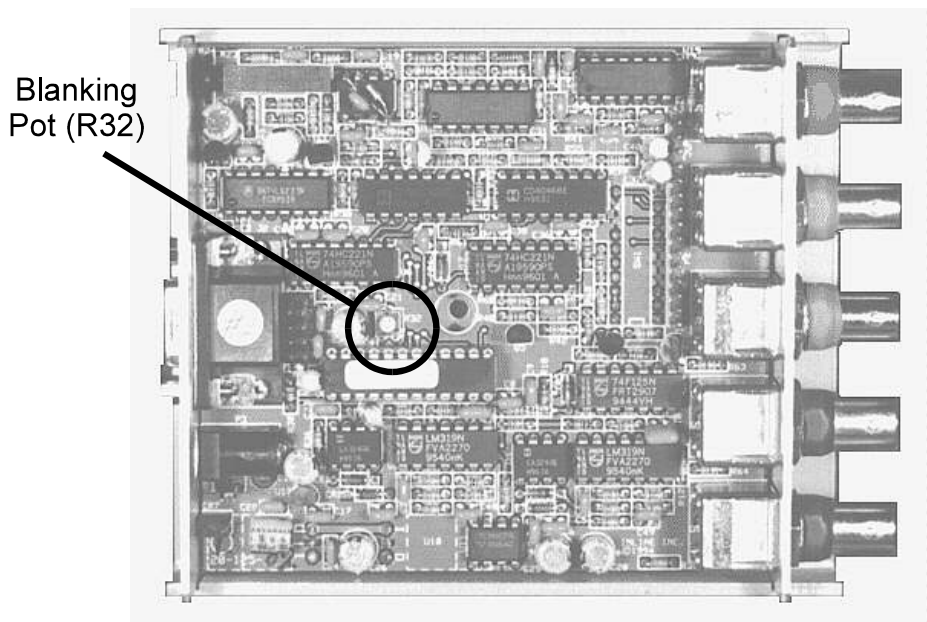

IN2005HR Internal View- Top Board

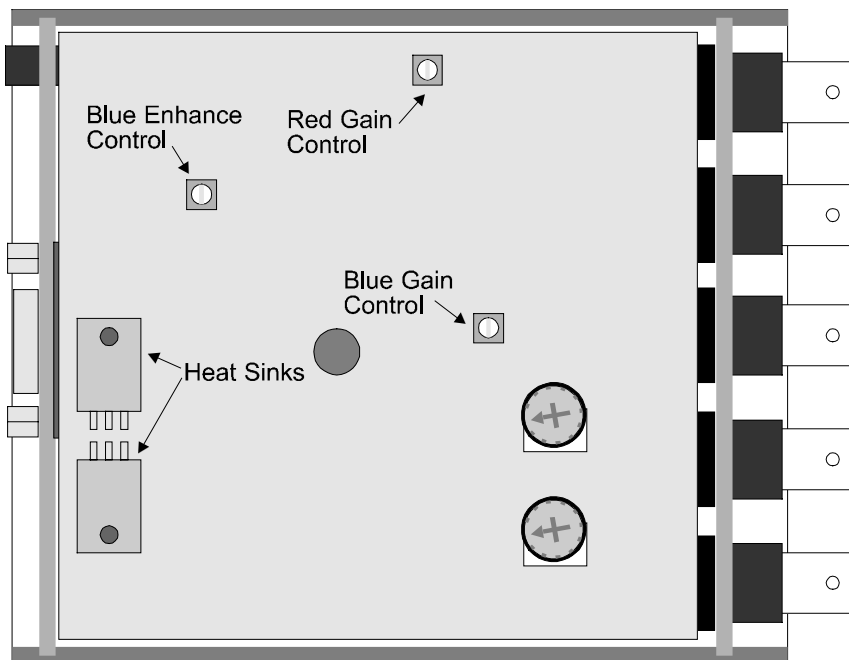

IN2025R / IN2015R POWER SUPPLY AND QUICK-CHANGE FUSES

The **IN2025R** and **IN2015R** feature a switch-mode (universal) power supply which operates automatically with A/C line conditions worldwide. The unit is compatible with A/C conditions from 90 - 260VAC at 47 - 63 Hz.

The **IN2025R** and **IN2015R** contain a 0.5A / 250V time delay fuse. To change the fuse, slide out the fuseholder using a small straight-slot screwdriver. This quick-change fuse holder has an active fuse and a spare fuse.

IN5100 SERIES MONITOR LOOP CABLES - PARTIAL LISTING

<u>Computer / Graphics Card</u>	<u>Cable Model</u>	<u>Connector</u>
IBM PC AND COMPATIBLES		
VGA / S-VGA / XGA / XGAII	IN5101A	15 Pin HD
VGA Buffered Input Module	IN5181B	15 Pin HD
CGA / EGA	IN5106T	9 Pin D
MDA / Hercules	IN5105T	9 Pin D
APPLE		
MACII / Quadra / Power MAC / Centris	IN5161A	15 Pin D
MAC Buffered Input Module	IN5182G	15 Pin D
MAC / MAC+	IN5107T	Internal Harness
MAC SE	IN5111T	Internal Harness
Apple IIE	IN5122T	9 Pin D
COMMODORE		
Amiga 500 / 1000 / 2000 / 3000 / 4000	IN5147A	23 Pin D
WORKSTATIONS & TERMINALS		
Sun Sparc Station	IN5160A	13W3
Sun / SGI Buffered Input Module	IN5183B	13W3
Sun Monochrome	IN5126A	9 Pin D
Silicon Graphics Iris Indigo	IN5175A	13W3
NeXT Color	IN5175A	13W3
NeXT Monochrome	IN5137A	19 Pin D
IBM 3192	IN5127A	25 Pin D
NCD 17C	IN5173A	26 Pin HD
1 - BNC - Monochrome	IN5132A	BNC
4 - BNC - RGBS or RGsB	IN5129A	BNC
5 - BNC - RGBH&V or RGsB	IN5133A	BNC
5 - BNC Buffered Input Module	IN5184B	BNC

IN2005HR / IN2015R / IN2025R Input Pin Configuration - 15 Pin HD Female Connector

Pin 1	Red Video	(Analog / TTL determined by Pins 14 & 15)
Pin 2	Green Video	(Analog / TTL determined by Pins 14 & 15)
Pin 3	Blue Video	(Analog / TTL determined by Pins 14 & 15)
Pin 4	Ground	
Pin 5	Ground	
Pin 6	Red Secondary	(TTL only)
Pin 7	Green Secondary	(TTL only)
Pin 8	Blue Secondary	(TTL only)
Pin 9	*Vertical Sync Input	
Pin 10	*Horizontal Sync Input	
Pin 11	Reserved	<i>(Do not connect anything to this Pin!)</i>
Pin 12	Ground	
Pin 13	Invert Video	(TTL Video Signals Only: Ground - Normal, Open - Inverted)
Pin 14	Analog / Digital Select	(Open - Digital, Ground - Analog)
Pin 15	Analog / Digital Select	(Open - Digital, Ground - Analog)

*Short Pins 9 & 10 together for Composite Sync input

INTERFACING TO COMPUTERS WITH BNC OUTPUTS

The **IN5129A**, **IN5132A**, and **IN5133A** are special input cables designed for use with workstations and terminals that have BNC video outputs. The chart below describes the input signal compatibility for each of these cables:

<u>Cable / Description</u>	<u>Monochrome</u>	<u>RGsB</u>	<u>RGBS</u>	<u>RGBH&V</u>
IN5129A 4 - BNCs		X	X	
IN5132A 1 - BNC	X			
IN5133A 5 - BNCs		X		X

Installation Procedure - IN5129A / IN5133A

The video signal input to the **IN2005HR / IN2015R / IN2025R** must be terminated into 75 ohms for proper image display. In order to achieve this termination the following installation procedure should be followed:

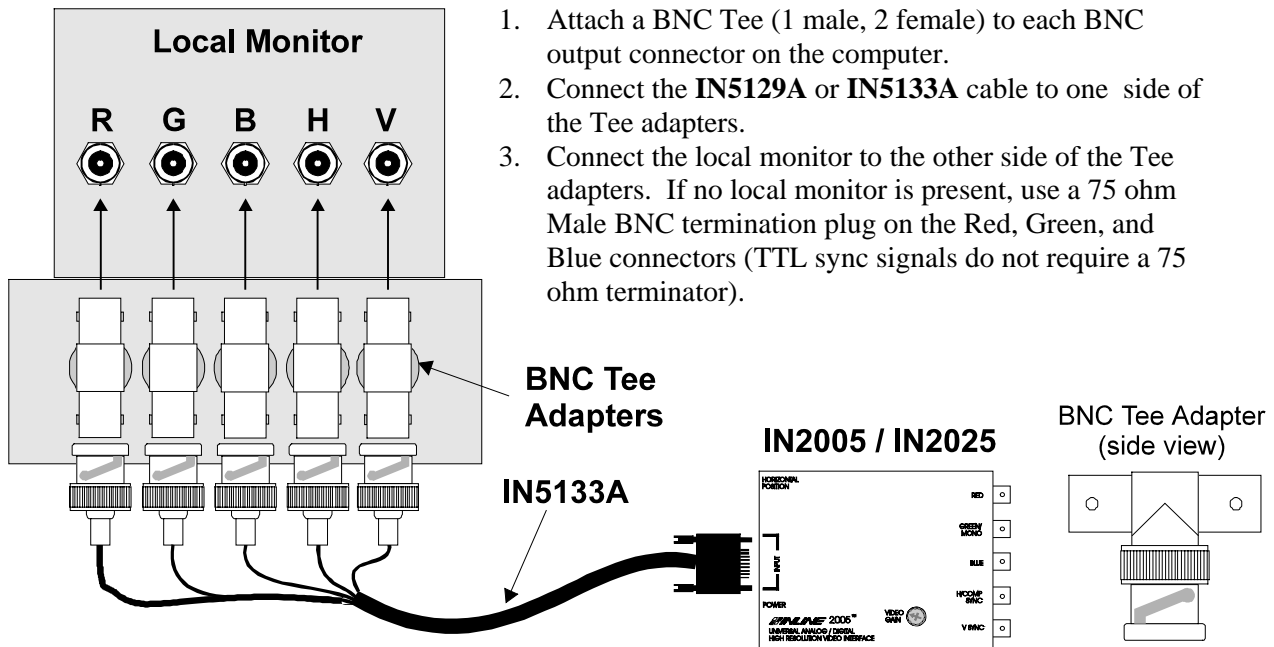

Installation Procedure - IN5132A

The **IN5132A** should be connected directly to the computer's monochrome composite video output. This cable includes an internal 75 ohm termination so the signal should not be split off to a local monitor before feeding it into the **IN5132A** or a double termination will result. If a local monitor is required, use one of the following methods to split the signal:

Looping Method - If the local monitor has a "Loop Out" connector, connect the monitor directly to the computer video output. Turn the Loop Out termination switch to "75 ohm termination OFF" and connect the **IN5132A** to the monitor's Loop Out connector.

Distribution Amplifier - use a high resolution distribution amplifier such as the **IN3212** to split the signal between the local monitor and the **IN5132A / IN2005HR, IN2025R** or **IN2015R**.

SPECIFICATIONS

	IN2005HR Universal Computer Video Interface	IN2025R / IN2015R Universal Computer Video Interface
Input		
Connector type	15 Pin HD Female - Proprietary Pin-Outs	
RGB Video Signals	Analog / TTL Digital / ECL Digital	
Input Impedance	High Impedance	
Maximum Input Voltage	Analog: ± 1.5 Vpp Digital: TTL Levels	
Sync Signals	0.2 to 5 Vpp	
Input Impedance	High Impedance	
Maximum Input Voltage	TTL Levels	
Horizontal Scan Range	15.0 kHz - 135.0 kHz	
Vertical Scan Range	30 Hz - 150 Hz	
Output		
Connector Type	5 BNC Female connectors - Red / Green / Blue / H / V	
Output Signal Formats	RGBH&V (Default), RGBS, RGsB, Monochrome and separate sync, Composite Monochrome	
RGB Signals	Analog Video, 75 ohm impedance	
Bandwidth	230 MHz @ -3 dB	
Rise and Fall Times	1.5 nano seconds	
Gain	Adjustable from 0.0 - 1.3	Adjustable from 0.7 - 1.3
Sync Signal	Sync output has AGC, 4V p-p unterminated and 2V p-p terminated into 75 ohms	
Horizontal Pulse Width	2.2 μ S @ 15.0 to 30.0 kHz 1.2 μ S @ 30.0 to 135.0 kHz	
Vertical Pulse Width	Same as Input Signal	
Controls		
External	Video Gain Horizontal Position Control DIP Switches Sharpness Control	Video Gain Horizontal Position Control DIP Switches Peaking Control
Internal	Horizontal Blanking Control	Horizontal Blanking Control
Dimensions		
Size	1.1" H x 5.2" W x 4.0" D	1.65" H x 8.5" W x 6.4" D
Shipping Weight	3 lb. / 1.5 Kg	4 lb. / 2 Kg
Power		
Power Supply	External AC to DC Power Transformer, 15V 600 mA Inline P/N: IN9206	Internal Switch-Mode Transformer 90 - 260 VAC; 47 - 63 Hz
Consumption	3 Watts	3 Watts
Regulatory Approval		
Safety	UL 1950, 3 rd Ed.; CE: EN60950-92; CAN/CSA-22.2 No. 950 3 rd Ed.	
EMI	FCC class A; CE: EN50081-1, EN55022, EN50082-1	

Parts and Accessories Included		
	IN2005HR IN9333 Adjustment Tool IN9206-X Power Supply Operation Manual	IN2025R / IN2015R IN9333 Adjustment Tool AC Power Cable (US only) Operation Manual

Optional Accessories	
IN5100 Series Input Cables	See Page 13 for a partial listing of available input cables. For a complete listing of IN5100 Series input cables see the current INLINE Product Catalog.
IN5180B Buffered Input Modules	See Page 4 for a complete list of available buffered input modules.
IN7000 Series RGBS / HV Cable	4 or 5 - BNC Cable available in a variety of lengths from 6' to 250'
IN7100 Series RGBS / HV Cable	4 or 5 - BNC High Resolution Cable, available in lengths from 6' to 250'
IN7200 Series RGBS / HV Cable	4 or 5 - BNC Ultra High Resolution HD Cable, lengths from 6' to 250'
The RGBS / HV cables above are available in longer lengths by custom order and may also be purchased in bulk quantities along with BNC connectors and crimp tools.	

TROUBLESHOOTING

The display device connected to the IN2005HR / IN2015R / IN2025R output has a bad/scrambled image.

Solution 1: Verify that the correct **IN5100 Series** input cable is being used.

Solution 2: The display device connected to the output of the interface may not be compatible with the computer output. CGA and EGA signals vary from 15.75 to 24 kHz. VGA runs at 31.5 kHz, but SVGA can be as high as 48 - 58 kHz with newer modes such as 1600 x 1200 running at 79 kHz. MACII/Quadra computers sense which monitor is connected and configure themselves accordingly with horizontal scan rates ranging from 24.48 to 68.9 kHz.

Solution 3: Check the DIP switch settings to make sure the unit is outputting a sync format that the display device can use. For most applications the default DIP switch settings (see Page 9) will work best.

Solution 4: The RGBS (or RGBH&V) cable may have a bad sync line. Try running the sync through another cable.

The output image is very dark.

Solution: The horizontal position control may be set off to an extreme position or may be interacting poorly with the horizontal position control on the display device. Follow the horizontal position adjustment procedure listed on Page 7.

The output image is missing a color.

Solution: Possibly the output RGBS or RGBH&V cable is bad. Try switching connections on the output to verify that the bad color's cable is OK (*Example:* If there is no red, try running the green output through the red cable and see if green is displayed or not.)

The output image is very bright and appears “overdriven” with poor contrast.

Solution 1: The loop through cable is probably being used without a local monitor and the signal is therefore unterminated. Use either a local monitor or a termination plug at the monitor loop-through connector on the **IN5100 Series** cable. If this is not the problem try #2.

Solution 2: Verify the gain setting on the **IN2005HR / IN2015R / IN2025R** gain pot. If it is set to a very high gain level, reduce the gain as required.

Solution 3: Check the contrast and brightness settings on the display device. Many CRT type display devices look best with the contrast set toward the upper end of the adjustment range (75 - 95%) and the brightness set towards the middle of the adjustment range (40 - 60%).

The output image is ghosting.

Solution: The **IN5100 Series** cables are designed to plug directly into the computer’s graphic card and a short (6 to 12 ft) monitor cable attached to the loop through output. An extension cable on the input or a very long monitor cable may cause this problem. Do not attempt to extend the length of the **IN5100 Series** monitor loop cable. Instead, replace the **IN5100 Series** cable with an **IN518x Series Buffered Input Module** (see page 4 for details).

When using the IN2005HR / IN2015R / IN2025R and an IN5101A cable with a VGA signal, the image from the output is violet with a very low green signal.

Solution: The local monitor may be monochrome. If it is a monochrome monitor, the **IN9030** mono adapter must be used - the output of the **IN2005HR / IN2015R / IN2025R** will be monochrome.

The output image from the IN2005HR / IN2015R / IN2025R has horizontal black bars throughout the image when interfacing to TTL video signals (IN5100 cables ending with "T").

Solution: The Horizontal Blanking Control may need adjustment. First check the Horizontal Position Control to ensure it is not causing the problem. If the problem persists, adjust the Horizontal Blanking Control according to the procedure on Pages 10 & 11.

The output image is too green.

Solution: The DIP switches may be set for Sync on Green output. Try changing the DIP switches to factory default settings (see Page 9) so the unit outputs an RGBHV signal.

IN2025R Only: When using the IN2025R set for RGsB output, there is no sync signal on Output B.

Solution: Only output A has an output signal when the IN2025R is set for sync on green output. You may use both Output A and Output B if you set the output sync to RGBHV or RGBS.

The output image is doubled, with two images displayed side-by-side.

Solution: The display device may not be compatible with the horizontal scan rate of the computer. This problem often occurs when a 31.5 kHz VGA signal is input to an RGB monitor that is only compatible with signals at 15.75 kHz.

If problems persist, call **INLINE Technical Services** at (800) 882-7117 or (714) 921-4100 for further assistance.

WARRANTY

- ◆ INLINE warrants the equipment it manufactures to be free from defects in materials and workmanship.
- ◆ If equipment fails because of such defects and INLINE is notified within two (2) years from the date of shipment, INLINE will, at its option, repair or replace the equipment at its plant, provided that the equipment has not been subjected to mechanical, electrical, or other abuse or modifications.
- ◆ Equipment that fails under conditions other than those covered will be repaired at the current price of parts and labor in effect at the time of repair. Such repairs are warranted for ninety (90) days from the day of re-shipment to the Buyer.
- ◆ **This warranty is in lieu of all other warranties expressed or implied, including without limitation, any implied warranty or merchantability or fitness for any particular purpose, all of which are expressly disclaimed.**

The information in this manual has been carefully checked and is believed to be accurate. However, Inline, Inc. assumes no responsibility for any inaccuracies that may be contained in this manual. In no event will Inline, Inc. be liable for direct, indirect, special, incidental, or consequential damages resulting from any defect or omission in this manual, even if advised of the possibility of such damages. The technical information contained herein regarding IN2005HR / IN2015R / IN2025R features and specifications is subject to change without notice.

IBM is a registered trademark of International Business Machines. Apple, MAC, Quadra and Centris, are registered trademarks of Apple Computers, Inc. Iris Indigo is a registered trademark of Silicon Graphics. Sun Sparc Station is a registered trademark of Sun Microsystems, Inc. All other trademarks and registered trademarks are the property of their respective companies.

© Copyright 1996 - 1998 INLINE, INC. All Rights Reserved

INLINE, INC. ◆ 22860 SAVI RANCH PARKWAY ◆ YORBA LINDA, CA 92887

800-882-7117 ◆ 714-921-4100 ◆ FAX 714-921-4160 ◆ www.inlineinc.com