

**OPERATION MANUAL
DEDICATED VIDEO INTERFACE SERIES**

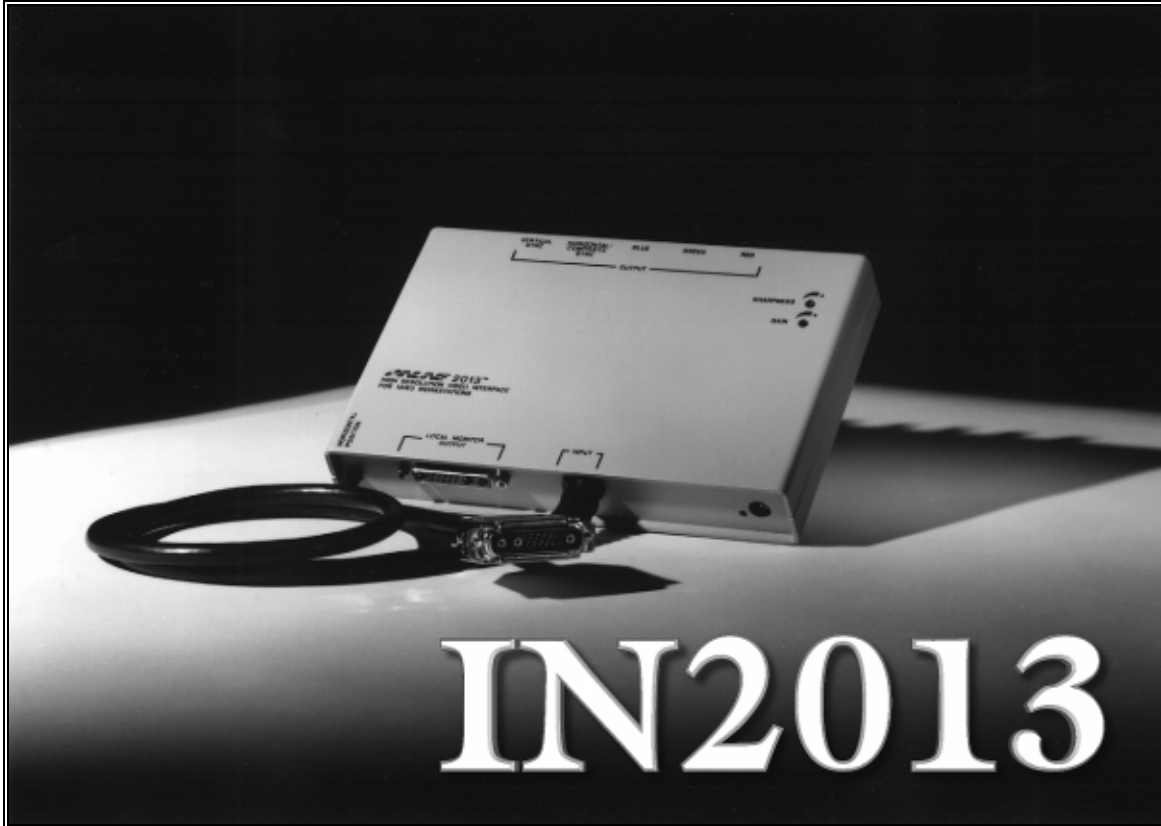

**IN2013 High Resolution Video Interface
for 13W3 Workstations**



TABLE OF CONTENTS

Product Overview	2 - 3
Description / Product Features	2
Input Compatibility / Output Compatibility	3
Installation	3 - 5
Input Computer Selection Dip Switch Chart	4
Diagram #1 - IN2013 Installation.....	5
External Controls	6 - 7
Horizontal Position Control	6
Sharpness Control	6
Gain Control.....	6
Monitor Emulation	7
Using the IN2013 With a Local Monitor	7
Using the IN2013 Without a Local Monitor	7
Monitor Emulation Chart	7
Internal Controls (For Technicians Only)	8 - 12
Opening the IN2013 Case	8
Diagram #2 - Internal View.....	9
Blue and Red Gain Controls.....	9
Diagram #3 - Dip Switches	10
Internal Dip Switches	11, 12
SW1 - Output Sync / Horizontal Position Control Disable	11
Select RGB Output or Composite Monochrome Output.....	11
Setting Output Sync Format - Automatic or Manual.....	11
SW2 - Monitor Emulation Switches	12
SW3 - Input Computer Select	12
Technical Reference	13 - 14
Specifications	13
Input / Local Monitor Output / Data Display Output	13
General: Controls / Power Supply / Power Consumption / Dimensions / Weight.....	13
Parts Included	13
Optional Accessories.....	13
Warranty.....	14

PRODUCT OVERVIEW

DESCRIPTION

The **IN2013** is a high performance dedicated computer video interface for Sun SPARC, SGI, IBM PowerPC, NeXT, and other graphic workstations with 13W3 video ports. Like other **INLINE** interfaces, the **IN2013** carries out three primary functions. This first function is signal splitting as the interface allows for the simultaneous connection and viewing of both the computer's local monitor and a second display device such as a large data monitor or data projector. The second function is physical interfacing and adaption. The **IN2013** connects to workstations with special video connectors (13W3) and provides output signal on standard BNC connectors. The final function is electronic interfacing. The interface accepts video in a wide variety of sync formats and converts the signal to RGsB, RGBS, or RGBHV as required by the display device, cabling, and video routing system.

PRODUCT FEATURES

- **Universal Compatibility for Graphic Workstations with 13W3 Video Ports**- The **IN2013** offers extremely flexible input signal flexibility for use with high performance graphic workstations. Factory set for automatic operation with Sun and SGI computers, the unit will accept other workstation signals by flipping one or two dip switches.
- **Exceptional Video Performance** - Featuring advanced video amplification circuitry, the **IN2013** offers video bandwidth in excess of 230 MHz, ensuring that even the highest resolution workstation video signals will be interfaced with complete signal clarity.
- **Buffered Local Monitor Output** - Ensures highest quality display on the local monitor. This buffered output provides the flexibility to place the local monitor anywhere since the monitor cable may be extended if necessary.
- **Automatic Output Sync Format Selection** - The **IN2013** senses the number of cables connected to the outputs at power up and automatically sets the output sync format to RGBHV, RGBS or RGsB. LED indicators located next to the Green, H/Comp Sync, and V Sync output BNCs provide clear visual confirmation of the current output sync format.
- **Flexible Monitor Emulation** - The interface is set at the factory to pass all sense pins through to the local monitor, ensuring that the graphics card sees the sense signals from the attached monitor and sets itself to the appropriate resolution, refresh rate or frequency. For applications where the **IN2013** will be used without a local monitor, dip switches are provided to emulate virtually any monitor.
- **Multi-Step Sharpness Control** - optimized to provide maximum visible sharpness enhancement with high resolution workstation video signals.

INPUT COMPATIBILITY

The IN2013 will accept high resolution video signals from Sun, Silicon Graphics, IBM PowerPC, NeXT and virtually any other graphic workstation which outputs analog video through a 13W3 female connector. Input signal compatibility parameters are listed below.

Video Signal:	Analog RGB Video
Connector:	13W3 female video port on computer
Signal format:	RGsB, RsGsBs, RGBS, RGBHV
Horizontal Frequency Range:	30 KHz to 130 KHz
Vertical Refresh Rates:	30 Hz to 120 Hz

OUTPUT COMPATIBILITY

The IN2013 outputs an analog RGsB, RGBS, RGBHV or Composite Monochrome signal on female BNC connectors. This output signal is compatible with high resolution data grade monitors and data / graphics projectors. While graphic workstations operate in several video modes encompassing a wide range of resolutions and scan rates, most of the video signals from these workstations have very high scan rates (60 KHz or more) and very high resolution (1280 x 1024 is common). The data projector or monitor must be compatible with the horizontal scan rate and vertical refresh rate of the workstation video signal. Please check the documentation for both the workstation graphics card and the data display device to ensure compatibility.

KEY CONCEPT

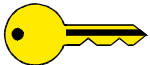

The IN2013 is not a scan converter or encoder. This unit does not change the horizontal scan rate, resolution, or convert the signal to NTSC composite video. The display device connected to the IN2013 output must be compatible with the horizontal scan rate, vertical refresh rate and resolution of the workstation video signal.

INSTALLATION

Installation steps are listed below and outlined in Diagram 1 on page 5.

#1 Turn the computer and computer monitor off.

Disconnect the computer monitor from the computer's video port.

#2 Check the Monitor Emulation dip switch settings on the bottom side of the IN2013.

Using Local Monitor - If you are using a local monitor (most installations) make sure that all dip switches in the box labeled MONITOR EMULATION are set to "0".

No Local Monitor - If you are not using a local monitor, gently set the dip switches using the Inline tool provided according to the chart found on page 7.

KEY CONCEPT



Check the Monitor Emulation chart and dip switch settings carefully. An improper setting of the emulation dip switches may lead to improper operation and could even result in severe damage to the computer video port or the monitor. If you are in doubt as to which monitor emulation to choose, set all the Monitor Emulation dip switches to "0" and connect a local monitor.

#3 Check the Input Computer Selection dip switch settings on the bottom side of the IN2013. The factory default setting (000) will work with Sun workstations and most SGI computers. If you have a different computer, carefully set the dip switches to the appropriate setting as indicated in the chart below using the Inline tool provided. *Please note that these settings only relate to the input signal from the computer and have no effect on the output sync format.*

Input Computer Selection Dip Switch Chart

Workstation	Dip Switch Setting
Sun	
RGBS (most common)	000
RGBHV	101
SGI	
RsGsBs (most common)	001 (000 also works)
RGBS	011
RGBHV	101 (001 also works)
NeXT Color (RGsB)	001
IBM PowerPC (RGBHV)	010

#4 Connect the IN2013 input cable to the computer's video port.

The input cable is the 3' long cable permanently attached to the interface. Connect this cable to the computer's video port (see drawing above).

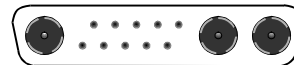

#5 Connect the local computer monitor (if present) to the LOCAL MONITOR OUTPUT on the IN2013. With no local monitor you may have to set the emulation dip switches (see page 7).

#6 Connect the IN2013 output to the display device RGB input.

Using high quality video cables, connect the output BNCs on the IN2013 to the RGB input on your large screen monitor or data projector. The interface will automatically set the output sync format according to the number of cables you have connected to the output:

Cables Connected to BNCs	Output Format
RGB	RGsB
RGBS	RGBS
RGBHV	RGBHV

Cable selection is extremely important to the performance of any high resolution graphics display system, especially when using long cable runs. The following Inline cables are available in a variety of lengths from 6' to 100' (longer cables available by special order) and are recommended for all system connections:

IN7000 Series Standard Resolution Coax Cables - 3, 4 or 5 conductors

IN7100 Series High Resolution Coax Cables - 3, 4, or 5 conductors

IN7200 Series Ultra High Resolution Coax Cables - 3, 4 or 5 conductors

#7 Apply power to the IN2013.

Connect the round connector on the provided power transformer to the power input jack on the IN2013 (US: **IN9207-1** 15VDC / 900mA, UK/European: **IN9208** 15VDC / 1A). Connect the power transformer to the A/C power source.

#8 Complete the installation by powering up the computer and computer monitor.

If necessary, adjust the horizontal position control as detailed on page 6.

DIAGRAM #1 IN2013 INSTALLATION

5

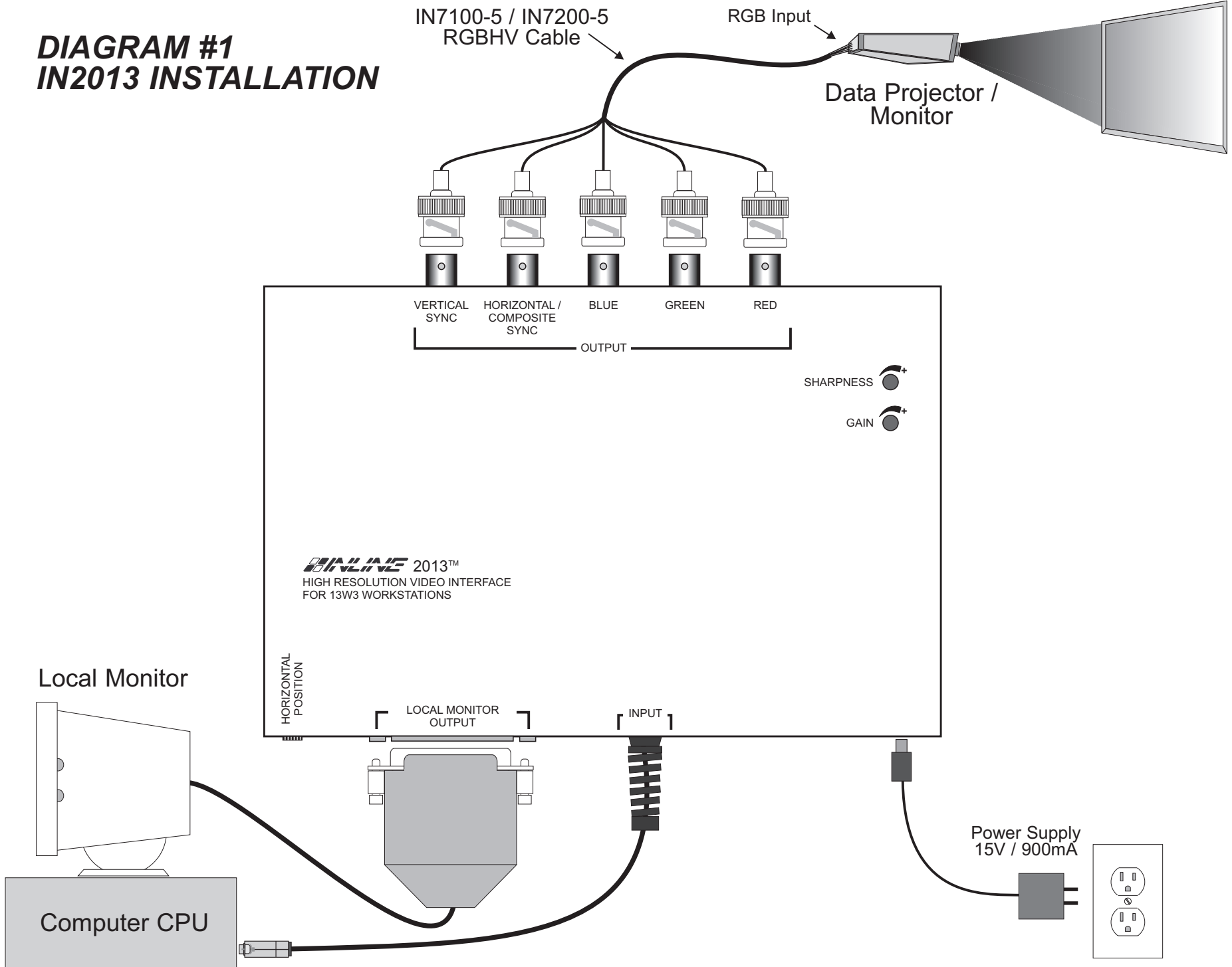

EXTERNAL CONTROLS

Once you have installed the **IN2013** as described in the previous section, operation is fully automatic. You may wish to make certain adjustments, however to optimize the interface for your computer video source and display device. All adjustments and settings described in this section are accessible via controls or dip switches on the top, bottom or side of the **IN2013**.

HORIZONTAL POSITION CONTROL

The horizontal position control is a small black knob located on the side of the **IN2013** adjacent to the Local Monitor Output connector. This control shifts the image to the left or to the right on the data display connected to the **IN2013** output (the local monitor is not affected). With an adjustment range of 15 turns from stop to stop, the horizontal position control allows for very fine horizontal centering control.

Most data projectors and monitors have their own image centering controls, and it is possible for the display device's horizontal position control setting to interact with the **IN2013** horizontal position control, resulting in a dark display, strange color reproduction or no image at all. The following procedure is recommended to ensure best results:

1. Adjust the **IN2013** horizontal position control so a good quality image is displayed. Avoid any extreme settings or any setting which causes the displayed image to darken.
2. Adjust the display device horizontal position control until the image is centered as desired.
3. If the image appears dark or the colors are not properly displayed, fine tune the controls on both the display device and the **IN2013** until the picture is centered and a good quality image is attained.

Disabling the Horizontal Position Control

For some installations you may wish to disable the horizontal position control. The control may be enabled or disabled by flipping a dip switch located on the bottom of the **IN2013**. Use the Inline adjustment tool to change dip switch settings. The factory default setting is horizontal position control enabled.

SHARPNESS CONTROL / GAIN CONTROL

The Sharpness and Gain controls are located on the top of the interface in the upper right hand corner. Both controls feature recessed control pots to increase durability and help prevent accidental changes to their settings. To adjust the Sharpness or Gain controls, insert the Inline adjustment tool into the desired adjustment control and turn gently. Turn clockwise to increase the value and counter clockwise to decrease the value. These adjustment pots have a rotational range of just over half a turn.

Sharpness Control

This control may be used to enhance the visibility of fine details by increasing the sharpness of the displayed image. The factory default setting is minimum (no sharpness enhancement).

Gain Control

The Gain Control adjusts the output voltage of the Red, Green, and Blue outputs simultaneously, ensuring that gray scale is maintained. The Gain adjustment range is .7 in the minimum position and 1.3 in the maximum position. The factory default setting is 1.0 (unity gain).

MONITOR EMULATION

Using the IN2013 With a Local Monitor

Many high resolution graphic workstations use sense signals to set resolution, horizontal frequency, and vertical refresh rate. The **IN2013** passes all sense pins between the computer video port and the local monitor attached to the Local Monitor Output, ensuring that the computer can sense the attached monitor and set itself to an appropriate resolution and scan rate for that monitor. **The Monitor Emulation dip switches must all be set to “0” when using a local monitor. This allows all sense pins to pass through, ensuring proper operation of the graphics card and monitor.**

Using the IN2013 Without a Local Monitor

The **IN2013** design makes it easy to use the interface without a local monitor. Because the Local Monitor Output port is buffered, there is no need for a termination plug to terminate the video signals when used without a local monitor.

The **IN2013** includes a bank of 10 dip switches on the bottom side of the interface for monitor emulation, permitting the interface to emulate virtually any type of monitor. By setting these switches to the appropriate positions, the user may emulate the appropriate sense signals, setting the video card to the desired frequency, refresh rate and resolution even without a local monitor.

If you are not using a local monitor, but need to emulate a specific mode, locate your workstation type and desired mode in the chart below. If you are not sure of the exact mode to select for your computer, select the mode shown in bold since it is the most common mode. Using the Inline adjustment tool provided with the interface, carefully set the dip switches to the appropriate settings. *Check the Monitor Emulation chart and the IN2013 dip switch settings carefully. An improper setting of the emulation dip switches may lead to improper operation and could even result in severe damage to the computer video port or the monitor. Some modes listed below may not be supported by certain workstations / graphic cards.*

Monitor Emulation Chart

Make / Mode	Dip Switch Settings
SUN	
1152x900 / 66 Hz / 61.8 KHz	0011000000
1152x900 / 76 Hz / 71.7 KHz - 16" / 17" Monitor	1001000000
1152x900 / 76 Hz / 71.7 KHz - 19" Monitor	1001000100
1280x1024 / 76 KHz / 81 KHz	1011000000
1600x1280 / 76 Hz / 100.8 KHz	0011000100
SGI	
Single Scan 15" (Indy) 1024x768 / 60 Hz / 48.48 KHz	0100000000
	or 0100000010
Single Scan 19" (Personal Iris / 4D) 1280x1024 / 60 Hz / 63.9 KHz	0000000000
Hitachi 19" 1280x1024 / 60 Hz	0100011000
Dual Scan 16" (Original Indigo) 1280x1024 & 1024x768 / 60 Hz / 63.9 & 48.48 KHz	0000010000
Dual Scan 19" (Original Indigo) 1280x1024 & 1024x768 / 60 Hz / 63.9 & 48.48 KHz	0100010000
Multiscan 16" Up to 1280x1024 / 76 Hz / 30 - 82 KHz	0100001000
	or 0100001010
Multiscan 19" Up to 1280x1024 / 76 Hz / 30 - 82 KHz	0000011000
	or 0000011010
Multiscan 21" Up to 1280x1024 / 76 Hz / 30 - 82 KHz	0000001000

INTERNAL CONTROLS

The controls needed for most installations and typical daily operation are all located on the exterior of the interface. A few controls for advanced options have been placed inside the unit. These controls are designed for qualified technicians and should not be adjusted by the casual user.

KEY CONCEPT



Internal control adjustment requires the IN2013 case to be opened, making the interface's sensitive electronic components vulnerable to physical damage or damage from static discharge. The case opening procedure as outlined below should only be carried out by qualified technicians located in an approved field force protective workstation. Physical damage to internal components and damage caused by static discharge is not covered under warranty.

OPENING THE IN2013 CASE

1. Remove power from the interface and place the unit in a static free environment to ensure protection to the internal components.
 2. Place the interface upside down on the work surface (rubber feet and dip switches facing up). Using a small Phillips screwdriver, remove the two screws on the bottom of the interface. Flip the interface back over to rest on the bottom side.
 3. Pull the top half of the interface case straight up.
 4. If you are only adjusting the Red and Blue gain controls no further disassembly is required. Make adjustments and reassemble the interface as described in steps 10 & 11. If you need to change the internal dip switch settings, continue with the steps below.
-
5. Remove the three Phillips screws (located in the corners and center on the input cable side of the interface) which hold the printed circuit board (PCB) to the lower case. To assist in reassembly, make note of the red ground strap terminal on the center screw.
 6. Lift the PCB / Input / Output connector assembly away from the lower case. Flip this assembly over to expose the dip switches on the underside of the PCB and place the assembly on a clean, flat surface, making sure that nothing touches the components on the PCB.
 7. Make dip switch adjustments as necessary.
 8. Flip the PCB assembly back over and place it back in the bottom half of the interface case, aligning the front and rear metal panels on the PCB assembly with the channels in the case bottom.
 9. Replace the 3 Phillips screws. Be sure to thread the center screw through the red grounding strap terminal before placing it in the PCB.
-
10. Replace the top metal case, carefully aligning the channels in the top metal with the front and rear metal panels on the PCB assembly.
 11. Carefully flip over the interface and replace the bottom screws.

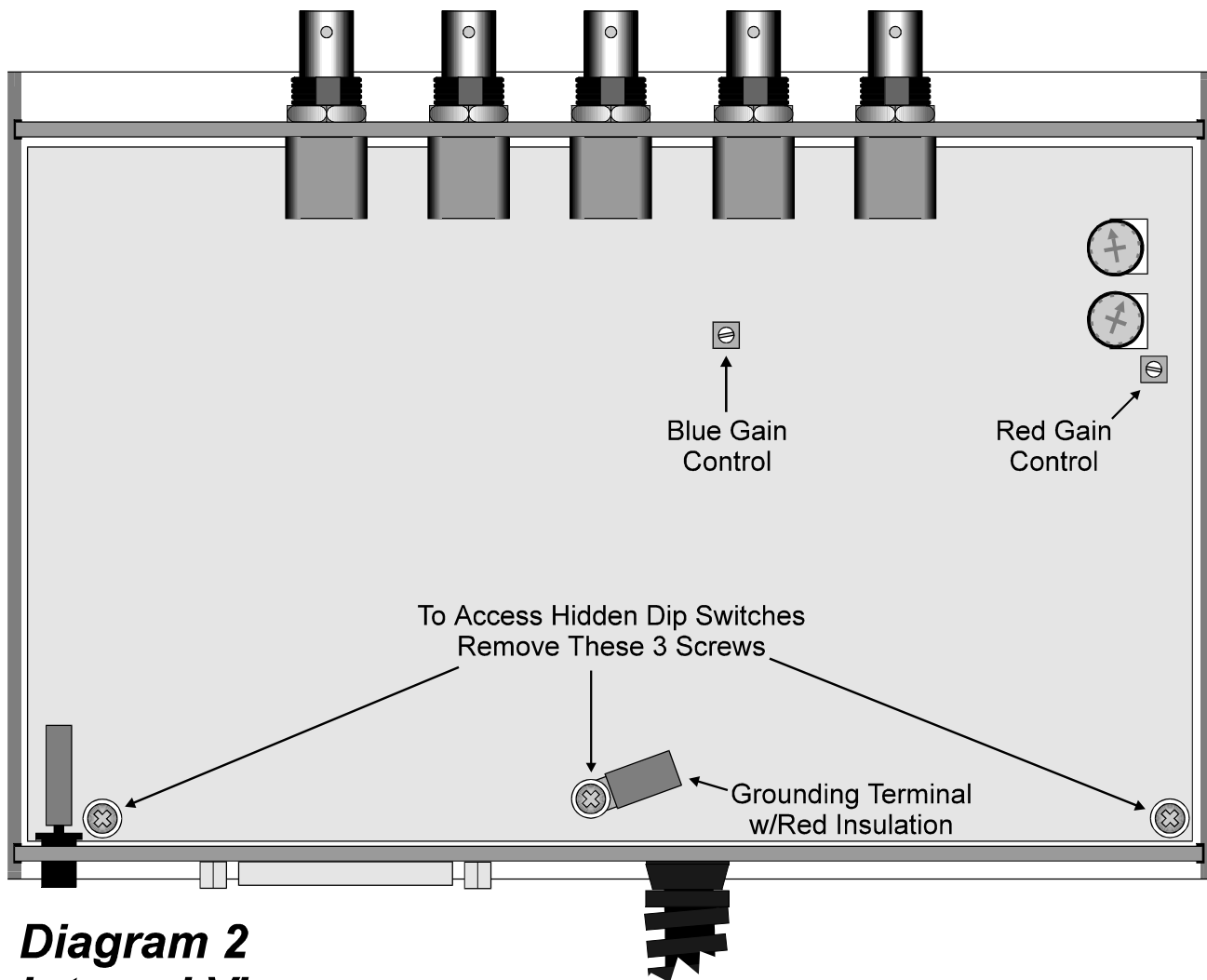

Diagram 2
Internal View

BLUE AND RED GAIN CONTROLS

The locations of the Blue Gain control (R182) and Red Gain control (R145) are shown in Diagram 2 above. These controls have been precisely calibrated at the factory to provide the same gain characteristics as the Green circuit.

Any adjustments made to the Blue or Red gain controls may adversely affect gray scale reproduction and color accuracy, therefore, these controls should only be adjusted by qualified technicians having the necessary test equipment. Since the gain pots must be adjusted with power applied to the interface, great care must be taken to avoid touching any exposed circuit paths and to avoid creating short circuits between adjacent components. The Blue and Red gain controls are light duty adjustment pots and should be carefully adjusted using a small plastic alignment tool.

- To increase the gain turn the adjustment pot counterclockwise.
- To decrease the gain turn the pot clockwise.

Diagram 3 - Dip Switches

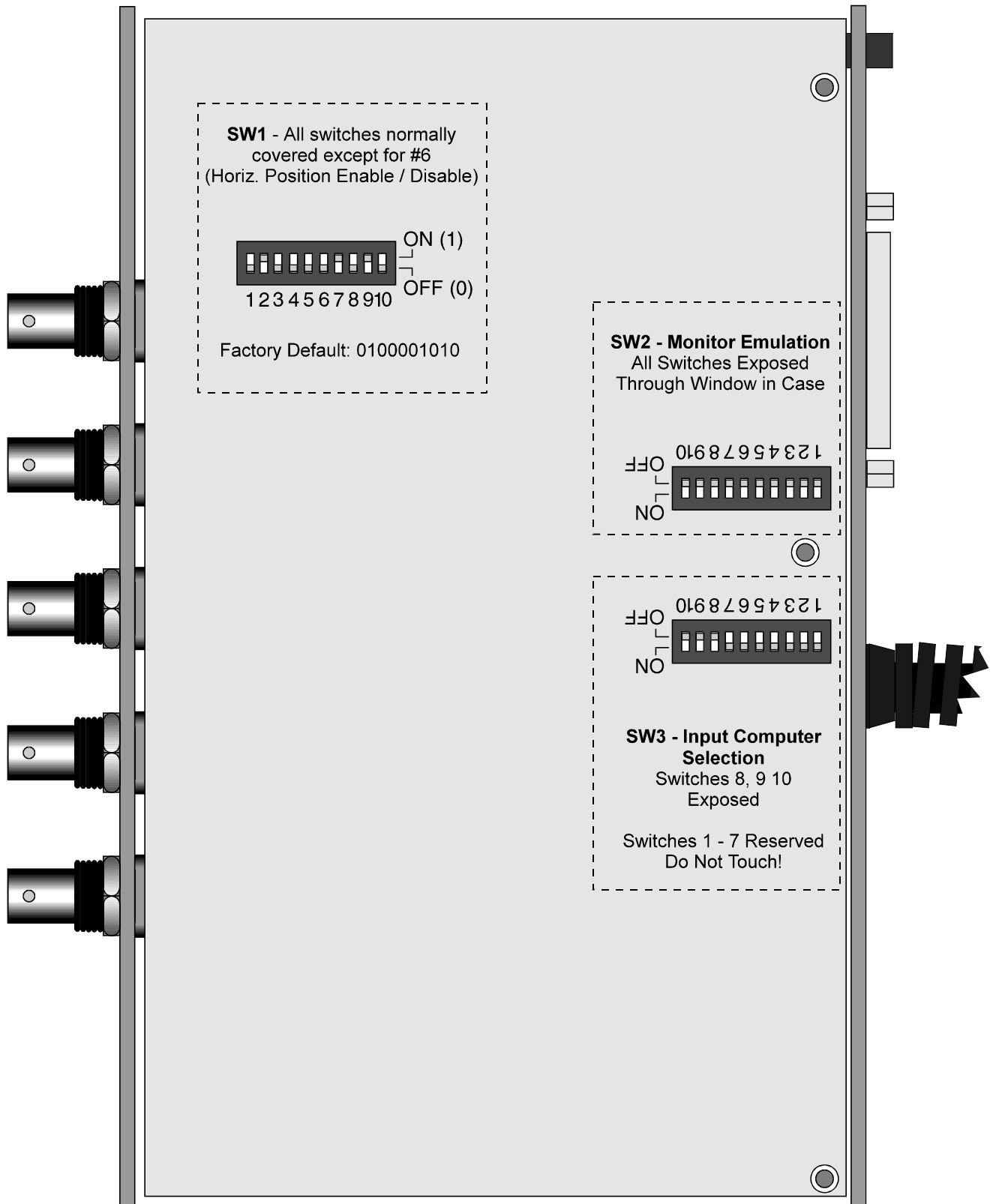

INTERNAL DIP SWITCHES

In order to simplify operation, the **IN2013** was designed so that dip switches needed by most users are exposed through windows in the case metal while reserved switches and other dip switches for highly specialized functions are covered. This helps prevent operational problems which might occur if the dip switches were set to unusual settings but also provides the flexibility so that advanced technicians may fully customize the interface settings if necessary. The **IN2013** will function properly for the vast majority of installations using the factory default dip switch settings for all hidden dip switches.

Hidden dip switches must only be adjusted by qualified technicians as this requires the interface to be opened and disassembled, raising the possibility of physical damage or static discharge damage to sensitive internal components (not covered under warranty).

The **IN2013** has three banks of dip switches as described below and shown in Diagram 3 on the preceding page. Dip switches are made of thin, soft plastic and should be gently adjusted using the Inline alignment tool provided or using another small tool.

SW1 - Output Sync / Horizontal Position Control Factory Default Settings: 0100001010

These dip switches are normally all covered except for #6.

Switch Number	Function When Set to ON (1)
1	N/C
2	Green Out (set opposite of Switch #3)
3	Monochrome Out (set opposite of Switch #2)
4	Manual Output Sync - RGBS (only works when #7 is set to OFF)
5	Manual Output Sync - RGSB (only works when #7 is set to OFF)
6	Horizontal Position Control Disable
7	Automatic Output Sync (Set to OFF for Manual Output Sync Select)
8	N/C
9	Reserved
10	N/C

Select RGB Output or Composite Monochrome Output

RGB Output (factory default)	#2 ON, #3 OFF
Composite Monochrome Output on the Green Connector (RGB summed together along with Sync)	#2 OFF, #3 ON

Setting Output Sync Format

The **IN2013** with factory default settings automatically sets the output sync according to the number of cables connected to the output BNCs. A green LED located next to three of the output BNCs indicates that sync is present and also indicates the current sync format. If desired, you may manually force the interface into a specific output mode. Please note that all 3 output LED indicators turn on when the interface is set to manual output sync mode.

Automatic Output Sync Selection (factory default)	#7 ON
Manual Output Sync Selection	#7 OFF
Select RGBHV Output Sync	#4 OFF, #5 OFF
Select RGBS Output Sync	#4 ON, #5 OFF
Select RGSB Output Sync	#4 OFF, #5 ON

SW2 - Monitor Emulation Switches**Factory Default Settings: 000000000**

These dip switches are normally exposed. Setting a switch to ON (1) grounds a specific pin on the input connector for purposes of monitor emulation. Setting a switch to OFF (0) passes the pin through the **IN2013**. If you don't know what to do, set all dip switches to 0. See pages 7 & 8 for detailed instructions.

Switch Number	Function When Set to ON (1)
1	Ground Pin 9
2	Ground Pin 2
3	Ground Pin 3
4	Ground Pin 4
5	Ground Pin 5
6	Ground Pin 6
7	Ground Pin 7
8	Ground Pin 8
9	Ground Pin 1
10	N/C

SW3 - Input Computer Select**Factory Default Settings: 111111000**

Switches 8, 9 & 10 on SW3 determine where the interface looks for sync on the input connector and what types of input sync it can accept. The factory default setting works with most Sun and SGI workstations. These dip switches are exposed through a window in the bottom case of the interface. For a detailed setting chart see page 4.

Important Note: #1 - #7 are normally covered because they must be left in the ON position. If any of these switches is set to OFF the interface will not pass through any sync.

Dip 8/9/10	Input Sync Format / Location	Computers
000	RGBS - Composite Sync on pin 5 (this mode also works with RGsB signals)	Sun SPARC
101	RGBHV - H. Sync on pin 6 / V. Sync on pin 2	Sun SPARC
001	RGsB only - ignores all other sync signals	NeXT / SGI
011	RGBS - Composite Sync on pin 3	SGI
100	RGBHV - H. Sync on pin 4 / V. Sync on pin 5	SGI
010	RGBHV - H. Sync on pin 5 / V. Sync on pin 9	IBM PowerPC

SPECIFICATIONS

INPUT

Connectors:	(1) 13W3 Male
RGB Signals:	Analog Video, 1.5 Vp-p max.
C. Sync / H&V Sync Signals:	TTL Compatible
Sync on Green Signals:	0.2 V - 0.4 V (sync portion)
Sync Format:	RsGsBs, RGSB, RGSB, RGBHV
Horizontal Sync Range:	30 KHz - 130 KHz
Vertical Sync Range:	30 Hz - 120 Hz

LOCAL MONITOR OUTPUT

(1) 13W3 female connector, buffered output - sync format same as input

DATA DISPLAY OUTPUT

Connectors:	(5) BNC Female
Gain:	Adjustable: .7 - 1.3
Horizontal Sync Pulse Width:	30 KHz - 40 KHz: 1.5uSec >40 KHz: .07 uSec
Vertical Sync Pulse Width:	Same as input signal +11 uSec
Bandwidth:	230 MHz @-3dB, .7 volt input signal

GENERAL

Controls:	Horizontal Position, Video Gain, Sharpness, Input Computer Select, Monitor Emulation
Power Supply:	US: IN9207-1 15VDC / 900mA UK/European: IN9208 15VDC / 1A
Power Consumption:	14.5 Watts
Dimensions:	1.3" x 8.4" x 5.6"
Product Weight:	2 lbs.
Shipping Weight:	5 lbs.

PARTS INCLUDED

- (1) IN2013 Interface
- (1) IN9207-1 or IN9208 Power Transformer
- (1) Inline Alignment Tool
- (1) Operation Manual

OPTIONAL ACCESSORIES

- IN7100-4 Series RGSB High Resolution Coaxial Cables**
- IN7100-5 Series RGBHV High Resolution Coaxial Cables**
- IN7200-3 Series RGSB Ultra High Resolution Coaxial Cables**
- IN7200-4 Series RGSB Ultra High Resolution Coaxial Cables**
- IN7200-5 Series RGBHV Ultra High Resolution Coaxial Cables**

All cables available in a variety of lengths from 6' to 250'

WARRANTY

- ◆ INLINE warrants the equipment it manufactures to be free from defects in materials and workmanship.
- ◆ If equipment fails because of such defects and INLINE is notified within two (2) years from the date of shipment, INLINE will, at its option, repair or replace the equipment at its plant, provided that the equipment has not been subjected to mechanical, electrical, or other abuse or modifications.
- ◆ Equipment that fails under conditions other than those covered will be repaired at the current price of parts and labor in effect at the time of repair. Such repairs are warranted for ninety (90) days from the day of re-shipment to the Buyer.
- ◆ This warranty is in lieu of all other warranties expressed or implied, including without limitation, any implied warranty or merchantability or fitness for any particular purpose, all of which are expressly disclaimed.

The information in this manual has been carefully checked and is believed to be accurate. However, Inline, Inc. assumes no responsibility for any inaccuracies that may be contained in this manual. In no event will Inline, Inc. be liable for direct, indirect, special, incidental, or consequential damages resulting from any defect or omission in this manual, even if advised of the possibility of such damages. The technical information contained herein regarding IN2013 features and specifications is subject to change without notice.

INLINE is a registered trademark of Inline, Inc. All other trademarks and registered trademarks are the property of their respective companies. Inline disclaims proprietary interest in the trademarks of others.

All Rights Reserved © Copyright 1995

INLINE, INC. ◆ 22860 SAVI RANCH PARKWAY ◆ YORBA LINDA, CA 92887
800-882-7117 ◆ 714-921-4100 ◆ FAX 714-921-4160 ◆ www.inlineinc.com