

OPERATION MANUAL INSTALLATION INTERFACE SERIES

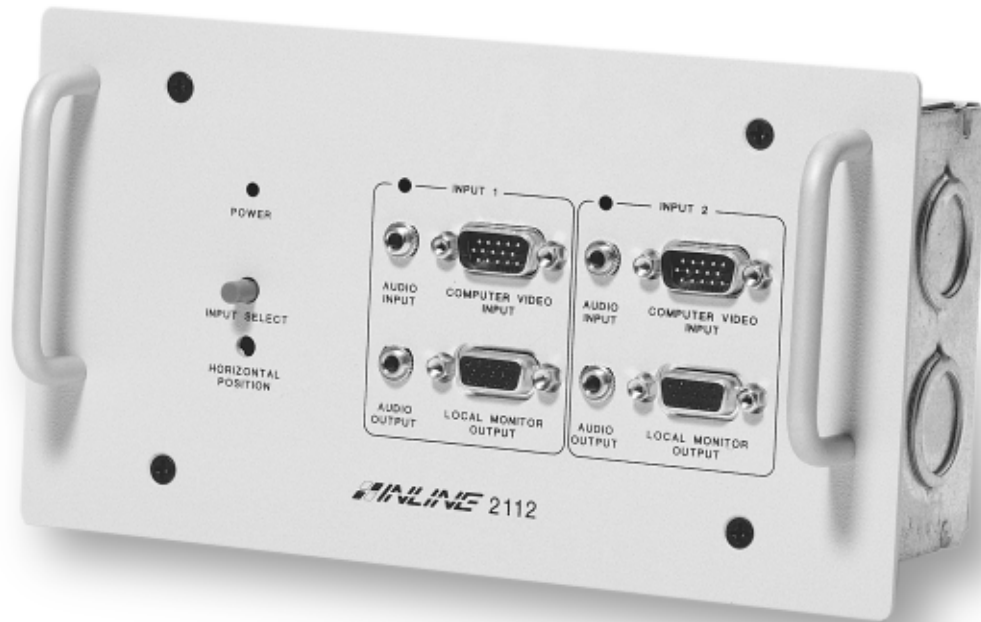

IN2112 High Resolution Installation Interface





Installation and Safety Instructions

For Models without a Power Switch:

The socket outlet shall be installed near the equipment and shall be accessible.

For Models with 110 / 220V Power Selector:

Caution: Before applying power to this unit, the voltage selector must be set to the appropriate setting to match local A/C line voltage. Improper setting of the voltage selector may cause damage to the unit and create a potential fire hazard.

The voltage selector is a round switch located next to the A/C power input connector which looks like this:

Using a straight slot screwdriver or small coin, rotate the selector to the correct position so that the arrow lines up with 110 or 220 as appropriate for local power line voltage as indicated in the chart below:

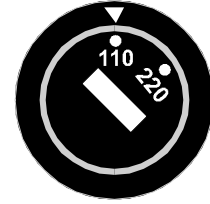

Local A/C Voltage	Voltage Selector Setting
110 ~ 120 VAC	110
220 ~ 240 VAC	220

For all Models:

No serviceable parts inside the unit. Refer service to a qualified technician.

For Models with Internal or External Fuses:

For continued protection against fire hazard, replace only with same type and rating of fuse.

For IN2001 / IN3234 / IN3236 / IN3502 / IN3504 / IN3506 / IN3562 / IN3564 / IN3566 / IN3572 / IN3574 / IN3576:

Caution: Double pole / neutral fusing.

For all Models with Integral Lithium Battery:

Caution: Danger of explosion if battery is incorrectly replaced. Replace only with the same or equivalent type recommended by the manufacturer. Dispose of used batteries according to the manufacturer's instructions.



Instructions d'installation et de sécurité

Pour les modèles sans interrupteur de courant:

La prise de courant d'alimentation sera installé près de l'équipement et sera accessible.

Pour les modèles avec un sélecteur d'alimentation 110V/220V:

Attention: Avant de connecter l'appareil au circuit d'alimentation, le sélecteur de courant doit être positionné sur la sélection appropriée correspondant au voltage du circuit de courant alternatif local. Une mauvaise sélection peut engendrer des dommages à l'appareil et créer un danger d'incendie.

Le sélecteur d'alimentation est un commutateur rond positionné près du connecteur d'alimentation. Il se représente comme suit:

A l'aide d'un tourne-vis plat ou d'une pièce de monnaie, le sélecteur peut être tourné dans la position adéquate en veillant que la flèche corresponde avec 110 ou 220, en fonction de la valeur du circuit de courant local. (Voir tableau ci-dessous)

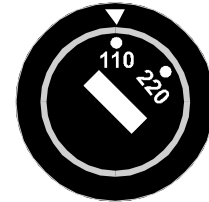

Circuit local AC	Position Sélecteur
110 ~ 120 VAC	110
220 ~ 240 VAC	220

Pour tout les modèles:

Pas de composants à entretenir à l'intérieur. Confiez toute réparation à un technicien qualifié.

Pour les modèles équipés de fusibles internes ou externes:

Afin d'éviter tout danger d'incendie, ne remplacer qu'avec le même type et la même valeur de fusible.

Pour IN2001 / IN3234 / IN3236 / IN3502 / IN3504 / IN3506 / IN3562 / IN3564 / IN3566 / IN3572 / IN3574 / IN3576:

Attention: Double pôle / fusible au neutre.

Pour tout les modèles avec une batterie au lithium interne:

Attention: Danger d'explosion si la batterie est incorrectement remplacée. Ne remplacez la batterie qu'avec le même modèle, ou avec un modèle recommandé par le constructeur. Traitez les batteries usagées selon les instructions du fabricant, ou selon les normes écologiques en vigueur.



Installations und Sicherheitshinweise

Für Geräte ohne Netzschalter:

Die Netzsteckdose soll in der Nähe des Gerätes installiert und frei zugänglich sein.

Für Geräte mit 110 / 220V Spannungswähler:

Achtung: Bevor Sie dem Gerät Spannung zuführen, muß der Spannungswähler entsprechend der Spannung des lokalen Wechselspannungsnetzes eingestellt werden. Die falsche Stellung des Spannungswählers kann eine Beschädigung des Gerätes und möglicherweise ein Feuer verursachen.

Der Spannungswähler ist ein runder Schalter in der Nähe der Netzeingangsbuchse mit folgendem Aussehen:

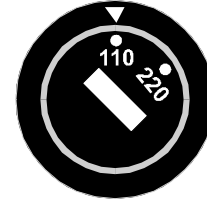

Drehen Sie den Wähler mit einem normalen Schraubenzieher oder einer kleinen Münze so, daß der Pfeil auf die 110 oder 220 zeigt, entsprechend der Spannung Ihres lokalen Netzes wie hier angezeigt:

Lokale Netzwechselspannung	Stellung des Spannungswählers
110 ~ 120 V	110
220 ~ 240 V	220

Für alle Geräte:

Keine Wartung innerhalb des Gerätes notwendig. Reparaturen nur durch einen Fachmann!

Für Geräte mit interner oder externer Sicherung:

Für dauernden Schutz gegen Feuergefahr darf die Sicherung nur gegen eine andere gleichen Typs und gleicher Nennleistung ausgewechselt werden.

Für IN2001 / IN3234 / IN3236 / IN3502 / IN3504 / IN3506 / IN3562 / IN3564 / IN3566 / IN3572 / IN3574 / IN3576:

Achtung: Allpolige Absicherung

Für alle Geräte mit eingebauter Lithium Batterie:

Achtung: Explosionsgefahr bei falschem Batterieeinsatz. Batterie nur ersetzen durch den gleichen oder entsprechenden Typ wie vom Hersteller empfohlen. Entsorgung verbrauchter Batterien nur nach den Anweisungen des Herstellers.



Instalacion E Instrucciones de Seguridad

Modelos Sin Interruptor:

La conexión debe ser instalada cerca del equipo y debe ser accesible.

Modelos con Selector de Voltaje de 110/220V:

Precaución: Antes de operar esta unidad, el selector de voltaje debe instalarse de forma que corresponda a la línea de voltaje local. Instalación inadecuada del selector de voltaje puede causar daño a la unidad y originar un incendio.

El selector de voltaje es un cambio vía redondo localizado cerca de la conexión eléctrica, como se ve en el dibujo:

Use un destornillador común o una moneda pequeña, mueva el selector a la posición correcta, de forma que las flechas indiquen 110 o 220 de acuerdo con el voltaje local, como está indicado a continuación.

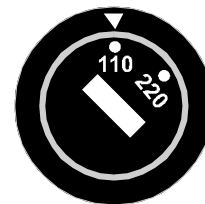

Voltaje Local A/C	Selector de Voltaje
110 ~ 120 VAC	110
220 ~ 240 VAC	220

Para Todos Los Modelos:

Dentro de la unidad, no hay partes para reparar. Llame un técnico calificado.

Modelos con Fusibles Internos o Externos:

Para prevenir un incendio, reemplace solo con el mismo tipo de fusible.

Modelos IN2001 / IN3234 / IN3236 / IN3502 / IN3504 / IN3506 / IN3562 / IN3564 / IN3566 / IN3572 / IN3574 / IN3576:

Precaución: Double Polo / Fusible Neutral.

Modelos con Batería de Lithium Interna:

Precaución: Peligro de explosión si la batería es reemplazada incorrectamente. Reemplace solamente con la misma clase de batería, o una equivalente recomendada por el fabricante. Deseche las baterías usadas de acuerdo con las instrucciones del fabricante.

CE COMPLIANCE

All products exported to Europe by Inline, Inc. after January 1, 1997 have been tested and found to comply with EU Council Directive 89/336/EEC. These devices conform to the following standards:

EN50081-1 (1991), EN55022 (1987)

EN50082-1 (1992 and 1994), EN60950-92

Shielded interconnect cables must be employed with this equipment to ensure compliance with the pertinent Electromagnetic Interference (EMI) and Electromagnetic Compatibility (EMC) standards governing this device.

**FCC COMPLIANCE**

This device has been tested and found to comply with the limits for a Class A digital device, pursuant to Part 15 of the FCC rules. These limits are designed to provide against harmful interference when equipment is operated in a commercial environment. This equipment generates, uses and can radiate radio frequency energy and, if not installed and used in accordance with the instruction manual, may cause harmful interference to radio communications. Operation of equipment in a residential area is likely to cause harmful interference, in which case the user will be required to correct the interference at their own expense.

DESCRIPTION

The **IN2112** is a high performance computer video interface for analog video signals including VGA, SVGA, XGA, MAC, SUN and other high resolution workstations. The **IN2112** mounts in a standard four-gang outlet box (included with the interface). The unit is available in two finishes: **IN2112B** - Black, **IN2112W** - White. Like other Inline interfaces, the **IN2112** performs the following functions:

Signal Splitting - allows the simultaneous connection and viewing of both the computer's local monitor and a second output device such as a large screen data projector, monitor, or color printer.

Physical Interfacing - Computers employ many different types of video output connectors, making it difficult to hook up computers directly to data projection devices. The **IN2112** simplifies interfacing, routing, and switching tasks by acting as universal adapters. Through the use of removable input cables, the **IN2112** can be attached to different computers and will provide a video output signal on five BNC connectors that can easily be connected to an RGB display device. The output signal format may be set to any of the following formats: RGBHV (default), RGSB, and RGSB.

KEY CONCEPT

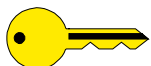

*The **IN2112** is not a scan converter. The data projector, monitor, or other output device must be compatible with the horizontal scan rate output by the computer video card.*

The **IN2112** installation interface offers easy operation and the following features:

- **Designed for Installation** - unit mounts in a wall, floor box, conference table, or podium
- **400 MHz Bandwidth** - High performance interface design ensures that video signals will be interfaced with no loss of image detail. Sufficient bandwidth for signals at any resolution.
- **Two Inputs** - connect two computers simultaneously and select the desired signal with the front panel input selector or remotely via contact closure. In auto-switch mode, the interface senses which input has an active signal and automatically switches to that input.
- **Stereo Audio Switching** - The **IN2112** features an audio input jack and local audio output jack for each input. The audio signal from the selected input is routed to the main audio output. The main audio output can be set for unbalanced or balanced audio signal.
- **Buffered Local Monitor Outputs** - provide a buffered output for each local computer monitor. This design provides the highest performance amplification and image quality, especially when used with very high frequency video sources.
- **15-Pin HD Standard VGA Connectors** - for input and local monitor output. VGA video cards and local monitors connect directly to the interface using standard VGA extension cables such as the IN8000 series. Adapter / Extension cables are also available for MAC, SUN and BNC.
- **Automatic Monitor Emulation** - when no local monitor is connected.
- **Flexible Output Signal Formats** - RGBHV (default), RGSB, and RGSB
- **LCD / DMD Friendly Output Sync** - By setting the interface to RGBHV output with mirrored input polarities, the unit provides minimal sync processing to ensure best operation with a wide variety of CRT, LCD and DMD displays. The horizontal position control can be disabled for additional sync preservation.
- **Horizontal Position Control** - allows picture to be centered precisely on the data display screen.
- **Serration Pulse Removal Switch** - enables the user to remove serration pulses from the sync output (RGSB / RGSB output only).
- **Protective Handles** - extend from the faceplate to protect the input / output connectors and attached cables from accidental damage.

INPUT COMPATIBILITY

The **IN2112** will accept high resolution video signals from virtually any computer that outputs an analog video signal. The unit will work with signals at virtually any resolution and refresh rate. Compatible computer video signals include VGA, SVGA, XGA, MAC, SUN, SGI and other high resolution computers outputting an analog video signal. Input signal compatibility parameters are listed below.

Video Signal:	Analog RGB Video
Signal format:	RGBHV, RGBS, RGsB*
Horizontal Frequency Range:	15 KHz to 135 KHz
Vertical Refresh Rates:	30 Hz to 130 Hz

KEY CONCEPT

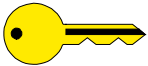

The **IN2112 will operate with RGsB input signals. However, the unit will not strip sync off of the green. RGsB input signals are always output as RGsB (they cannot be output as RGBS or RGBHV). Also, the horizontal position control will not operate when used with RGsB input signals.*

OUTPUT COMPATIBILITY

The output signal of the **IN2112** is analog RGB video with TTL sync on 3, 4 or 5 female BNC connectors. The output format can be set to RGBHV, RGBS, or RGsB using dip switches. This output signal is compatible with high resolution data grade monitors and data / graphics projectors.

KEY CONCEPT

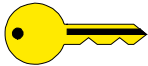

VGA, MAC, SUN, SGI and other high resolution workstations operate in several video modes encompassing a wide range of resolutions and scan rates, and many of the video signals from the newest models may have very high scan rates (70 KHz or more) and very high resolution (1600 x 1200 is now common). The data projector or monitor connected to the interface output must be compatible with the horizontal scan rate and vertical refresh rate of the computer's video signal. Please check the documentation for both the computer graphics card and the data display device to ensure compatibility.

ADAPTER / EXTENSION CABLES FOR INPUT AND LOCAL MONITOR OUTPUT

The **IN2112** has 15-Pin HD VGA-type connectors for input and local monitor output. The following input and local monitor output cables are available to support a variety of computers and local monitors.

Computer	3'	6'	12'	25'
VGA: 15-Pin HD				
Input Cable	IN8003	IN8006	IN8012	IN8025
Output Cable (optional)	IN8003	IN8006	IN8012	IN8025
MAC: 15-Pin D				
Input Cable		IN9140		IN9144
Output Cable	IN9141			IN9145
SUN: 13W3 (may also be used with SGI with RGsB output)				
Input Cable		IN9142		IN9146
Output Cable	IN9143			IN9147
Workstation: 5 BNC				
Input Cable (RGBHV / RGsB)		IN9048	IN9046	
Output Cable (All Formats)		IN9047	IN9045	
Workstation: 4 BNC - RGBS				
Input Cable (RGBS Only)		IN9100		

INSTALLATION

CAUTION: *Installation of the IN2112 must only be carried out by qualified technicians. Care must be taken to avoid static shock to the internal components.*

This section offers step-by-step instructions for installing the **IN2112**. The installation diagrams on Pages 4 - 6 show the location and function of the **IN2112** connections and jumpers.

1. Install the junction box in accordance with standards set forth in the National Electrical Code. Secure the junction box with nails (2 places minimum) if mounting to a wooden stud or self-tapping screws when attaching to a metal stud. You may also install the interface in an existing 4-gang junction box. Run the video coax cable, power cable and stereo audio cables (if used) to the junction box.
2. Set the dipswitches as appropriate for your installation (see Page 8 for more details). The **IN2112** factory default output format is RGBHV. If your display device, routing system, or cabling require a different format, use the dip switches to change the output signal to RGBS or RGSB as desired. For best results with LCD / DMD displays, use the dipswitch settings indicated on Page 4.
3. Connect the **IN2112** output (5 BNC connectors) to the data display device's RGB input, using three, four, or five high resolution BNC cables or a multi-conductor RGBHV, RGBS, or RGB "snake". The **IN7000 Series**, **IN7100 Series** and **IN7200 Series** high resolution cables are well suited for this purpose. Take care while making connections to ensure that the red output is connected to the red input, green output to the green input, etc. (see diagram on Page 6).
4. Connect the audio cable to the appropriate pins on the **IN2112** 5-pin Phoenix connector. Make sure that the four jumpers located near the audio output connector are set to the appropriate position for unbalanced or balanced stereo audio output as required by the installation (see Page 5 for more details). The factory default setting is unbalanced audio output. Connect the audio output wires to the appropriate connectors:
 - Unbalanced Output** - connect to the Left, Right and Ground connectors.
 - Balanced Output** - connect to Left +, Left-, Right+, Right- and Ground connectors.
5. Connect the power cable to the unit. **The same 7-pin captive screw connector is used for both power and remote control connections. Make sure you look at the labels silk screened on the PCB to determine the correct pins for power connection. The IN2112 requires +5V, +12V, -12V and ground for proper operation. Be extra careful to connect the various voltages to the correct pins on the connector. Connecting the power to the wrong pins or connecting with reversed polarity may permanently damage the unit! If in doubt, measure the power cable with a voltmeter to verify positive and negative.** The **IN9212** +5VDC, ± 12 VDC power supply (included) will power one **IN2112**. The power cable used to connect the power supply to the interface should be 18 gauge to 22 gauge, depending on the length of the cable. Inline offers the **IN8500P-4** power cable, an 18 gauge, 4-conductor, plenum rated cable.
6. If the **IN2112** will use remote input selection, connect the remote control cables to the **SWGND** (Switch Ground) and **SW2** pins on the 7-Pin Phoenix connector. The remote connector requires a latching connection and works in conjunction with the front panel selector switch. Each time the remote connector circuit is opened or closed the **IN2112** will select the opposite input. This could be either input 1 or input 2 depending on which position the front panel switch is in. The **IN2112** remote connector has a **STATUS** pin which can provide feedback to a control system or remote button to indicate which input is currently selected. When the **STATUS** pin is low, this indicates that Input 1 is currently selected. If the **STATUS** pin is high, Input 2 is selected.
7. Carefully attach the **IN2112** to the outlet box being sure no cables are pinched or damaged.
8. Turn the computer and computer monitor off. Disconnect the computer monitor (if present) from the video output port on the computer.
9. Connect the local computer monitor (if present) to the local monitor output of the **IN2112**. VGA monitors will attach directly to the local monitor output. For other types of monitors, use the appropriate local monitor output adapter cable (see list on Page 2). The unit automatically emulates a VGA / MAC 13" monitor with factory default settings. In order to override automatic emulation, set the dip switch settings as shown on Page 8.

10. Connect the computer graphics card video output to the **IN2112** Input using the appropriate input cable (see list on Page 2).
11. Connect the computer sound card output (if present) to the audio input connector using an **IN9106** audio patch cable. For computers with RCA connectors, use the **IN9107** audio adapter cable. Connect powered local speakers (if present) to the local audio outputs.
12. Complete the installation by turning the computer and computer monitor on. If required, adjust the horizontal position control to center the image on the data display device.

IN2112 REAR PANEL (PCB) CONNECTORS AND JUMPERS

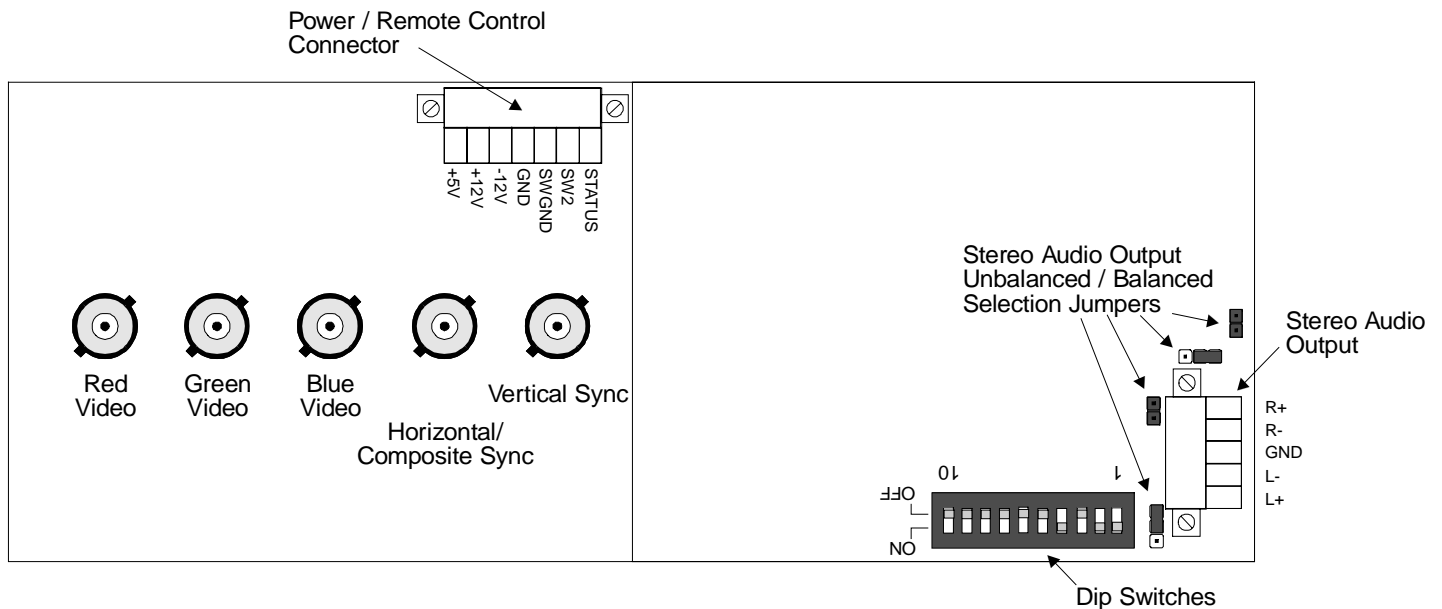

OPTIMAL SETTINGS FOR LCD / DMD DISPLAYS

The following output sync settings provide maximum sync signal preservation and are recommended for best image quality with LCD and DMD display devices. Depending on the design of the display device's sync processing circuitry, you may be able to set the horizontal position control to the enabled position, however, experimentation with your display device is the best way to determine whether you can achieve a stable image with the horizontal position enabled. Most LCD displays include a fine phase control, which can be adjusted to optimize picture quality.

Dip Switches Setting: #2 Set to ON / All other dip switches set to OFF

Signal Format: Red / Green / Blue / Horizontal and Vertical Sync

Horizontal Position Control: Disabled

H & V Sync Polarity: Mirror Input Polarities

STEREO AUDIO SWITCHING

The IN2112 provides stereo audio-follow-video switching to accommodate stereo audio signals from a computer audio card or other stereo audio sources. Whenever Input 1 or Input 2 is selected, the corresponding stereo audio signal is routed to the audio output connector on the back of the interface, which is normally connected to a house sound system.

AUDIO INPUTS

One 3.5mm female stereo mini jack is provided for each input. The input signal can be mono or stereo unbalanced audio (line level or 8 ohm).

AUDIO OUTPUTS

One 3.5mm female stereo mini jack is provided for each local output. The audio output connectors on the front of the interface provide a passive loop-out signal from the **AUDIO INPUT** connector. The audio output connectors can drive local powered speakers. If the input signal is line level, the local audio outputs can also be connected to a local recording device. Signal is always passed from the input to the local audio output whether that input is currently selected or not.

MAIN STEREO AUDIO OUTPUT

One 5-pin captive screw terminal is provided on the back side of the interface for stereo audio output (for location, see diagram on page 4). This connector outputs an audio signal from either Input 1 or Input 2 depending on which input is currently selected. The main audio output is set at the factory for unbalanced audio signal. The output can be set for either unbalanced audio or balanced audio by setting four jumpers located immediately adjacent to the 5-pin stereo audio connector as indicated below. When the unit converts an unbalanced input signal to balanced output, the gain remains constant.

For Unbalanced Stereo Audio Output

- Set both 2-Pin jumpers to closed.
- Set the two 3-Pin jumpers as shown in diagram on the right.
- Make connections between the output connector and the sound system as diagrammed here.

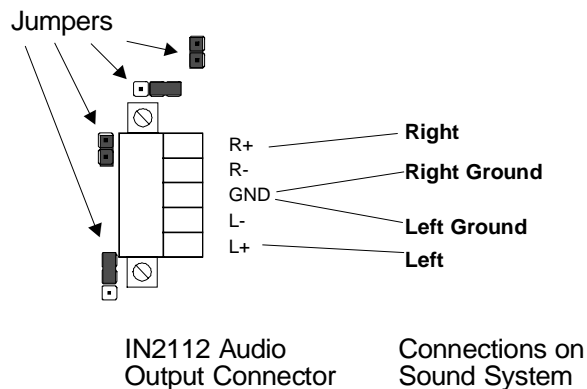

For Balanced Stereo Audio Output

- Set both 2-Pin jumpers to open.
- Set the two 3-Pin jumpers as shown in diagram on the right
- Wire the output connector as diagrammed here.

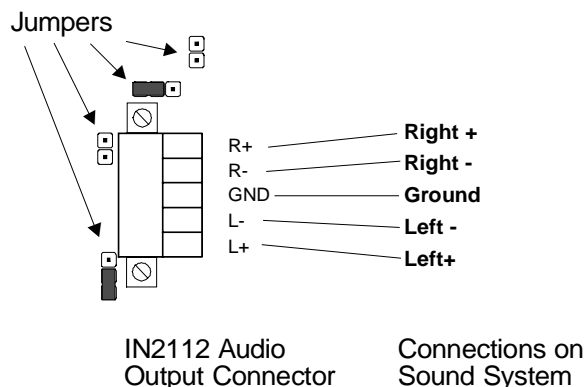

IN2112 APPLICATION DIAGRAM

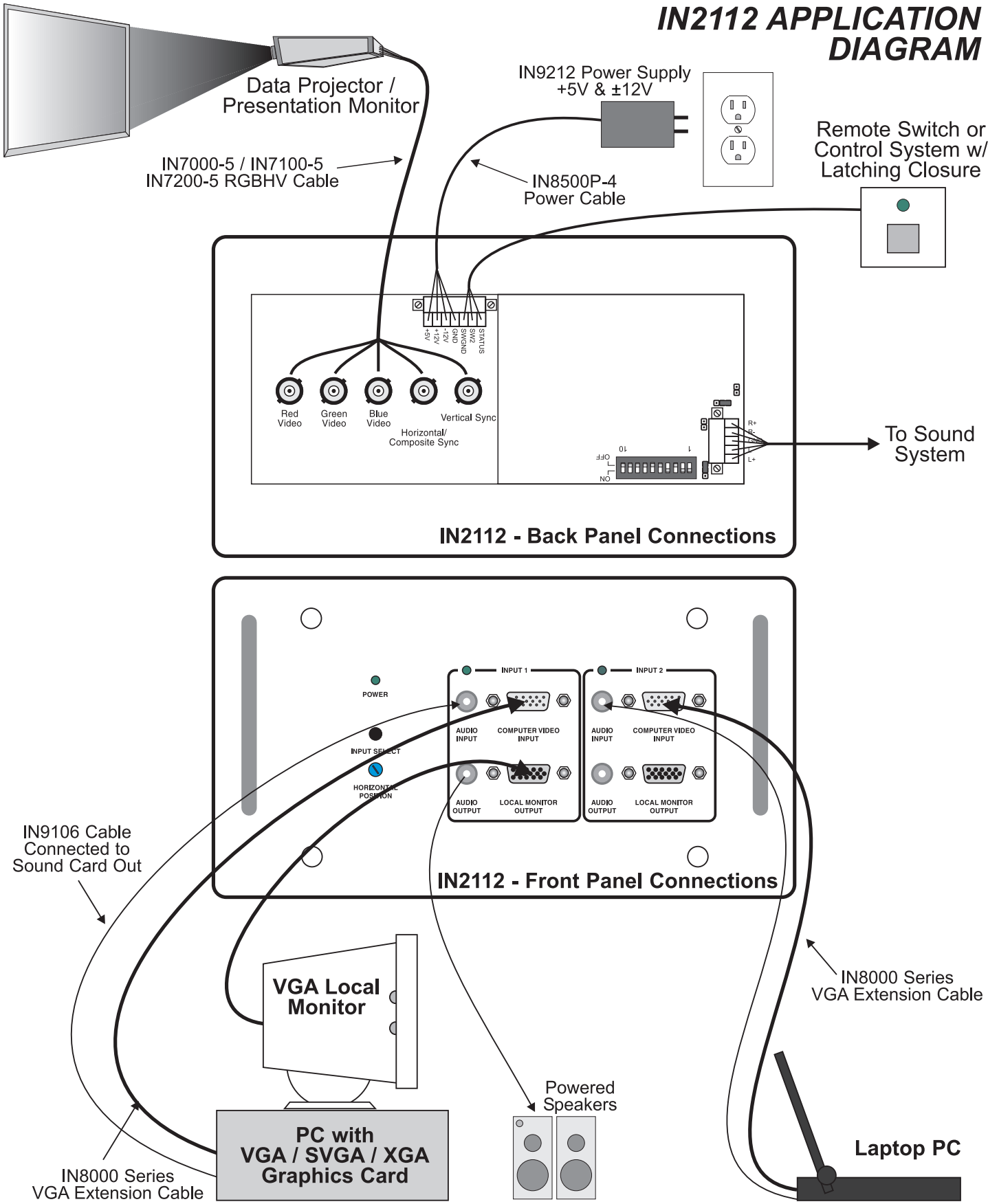

IN2112 FRONT PANEL CONNECTORS AND CONTROLS

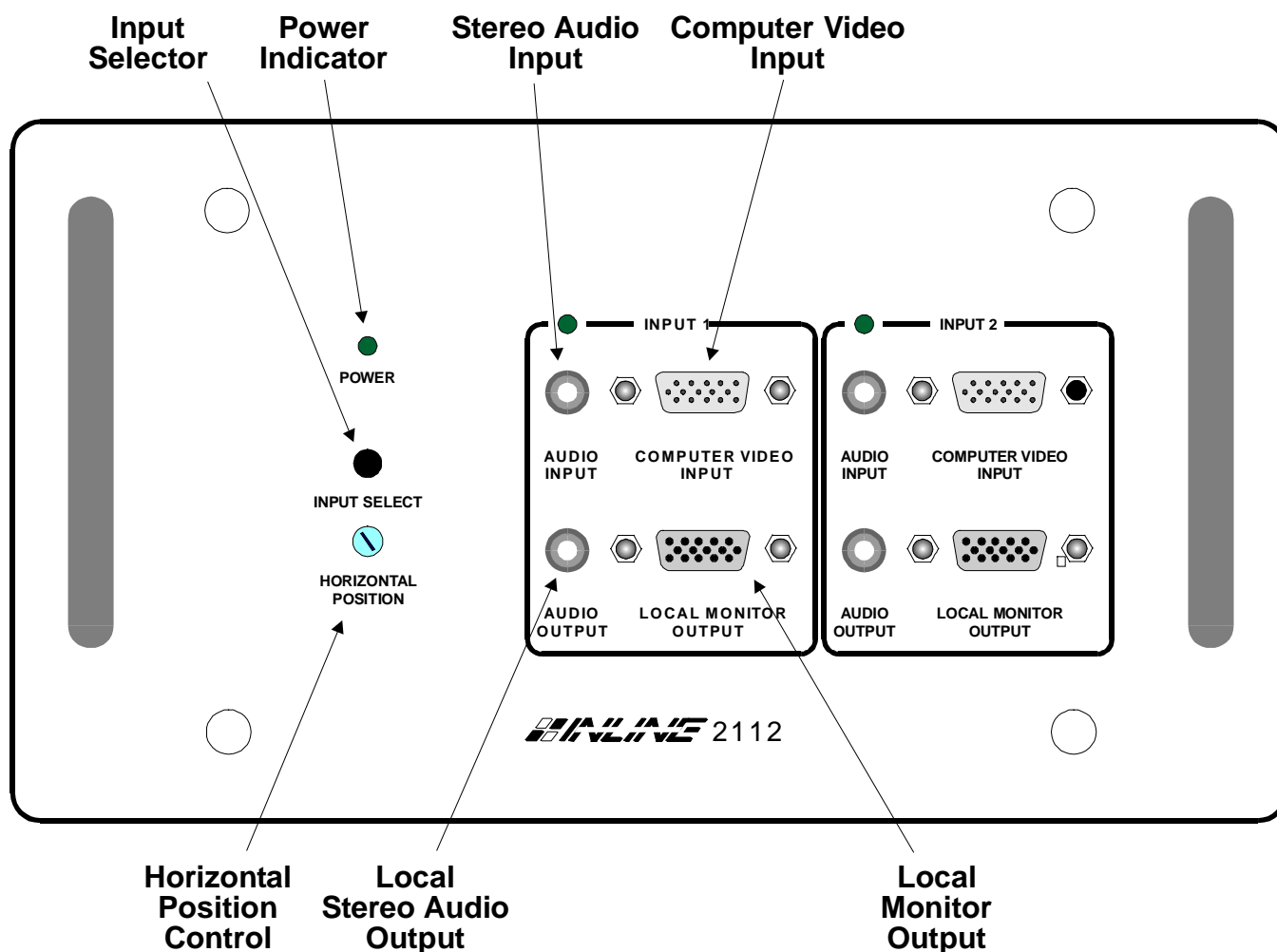

HORIZONTAL POSITION CONTROL

The location of the horizontal position control is indicated in the diagram above. The horizontal position control adjusts the position of the image on the data display device from left to right (it has no effect on the local computer monitor).

Most data projectors and monitors have their own horizontal position control, and the interaction of the display device's horizontal control and the interface's horizontal control may result in a dark image on the data display. The following procedure is suggested to ensure best results:

1. Adjust the **IN2112** horizontal position control so a good quality image is displayed. Don't worry about centering the image, just look for the setting which provides the best quality image. The horizontal position control should not be set to an extreme position.
2. Adjust the display device horizontal position control until the image is centered as desired.
3. If the image appears dark or the colors are not properly displayed, fine tune the controls on both the display device and the interface until the picture is centered and a good quality image is attained.

DIP SWITCH SETTINGS

Most installations will not require any changes to the dip switch settings, and the **IN2112** will generally be operated with the factory default settings. The Factory Default settings and specialized dipswitch settings are indicated below. Please note that when the interface is held upright, the dipswitches are numbered from 10 to 1 as shown below.

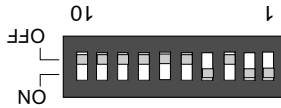

Factory Default Settings

Dip Switches ON:	1, 2, & 4
Signal Format:	Red / Green / Blue / Horizontal and Vertical Sync
Horizontal Position Control:	Enabled
H & V Sync Polarity:	Negative, Negative
Serration Pulse Generator:	Serration Pulses Enabled
Monitor Emulation Input 1:	Auto Termination Enabled
Monitor Emulation Input 2:	Auto Termination Enabled
Autoswitching:	Disabled

The table below lists the functions of the 10 dip switches:

Switch	Function	Setting
1	Horizontal Position Control	On Horizontal Position Enabled* Off Horizontal Position Disabled
2	Output Sync Format Selection: Select Sync on Green or Separate Sync	On RGBS / RGBHV* Off Sync on Green
3	Output Sync Format Selection: Select RGBS or RGBHV	On RGBS Off RGBHV* (Switch 2 must be On in order to get RGBS or RGBHV Output Format)
4	RGBHV Output Polarity	On Negative Sync Polarities* Off Mirror Input Polarities
5	Serration Pulse Generator	On Serration Pulses Disabled Off Serration Pulses Enabled*
6	Input A Monitor Emulation - Pin 11	On Pin 11 Always Grounded Off Pin 11 State Set by Auto Termination*
7	Input A Monitor Emulation - Pin 10	On Pin 10 Always Grounded Off Pin 10 State Set by Auto Termination*
8	Input B Monitor Emulation - Pin 11	On Pin 11 Always Grounded Off Pin 11 State Set by Auto Termination*
9	Input B Monitor Emulation - Pin 10	On Pin 10 Always Grounded Off Pin 10 State Set by Auto Termination*
10	Input A/B Auto-Switch	On Auto-Switch Enabled Off Auto-Switch Disabled*

*Factory Default Settings

SPECIFICATIONS

Inputs	
Video	Connectors: (2) 15 Pin HD male
RGB Signals	Analog, 0.7 Vp-p Nominal Input Impedance: 75 Ohms
Sync Signals	TTL compatible
Horizontal Scan Range	15.0 KHz - 135.0 KHz
Vertical Scan Range	30 Hz - 130 Hz
Stereo Audio	Connectors: (2) 3.5mm Stereo Mini Female Signal: Unbalanced Line Level; $\pm 5V / \pm 30$ mA max.
Outputs	
Buffered Local Monitor	(2) 15-Pin HD female - standard VGA pin-outs
Main Output	5 BNC Female connectors
Output Signal Formats	RGBHV - Negative Sync Polarities (Default), RGBHV - Mirror Input Sync Polarities, RGBS or RGsB
RGB Signals	Analog Video, 75 ohm impedance
Bandwidth	400 MHz @ -3 dB
Rise and Fall Times	0.875 nano seconds
Gain	$1.0 \pm 5\%$
Sync Signal	H, V and S: 4V unterminated; 2V when 75 ohm terminated Gs: 0.3V when 75 Ohm terminated
Horizontal Pulse Width	Horizontal Position Enabled: approximately 1.5 μ sec Horizontal Position Disabled: Approximately the same as the input signal
Vertical Pulse Width	Approximately the same as the input signal
Local Audio Outputs	(2) 3.5mm Stereo Mini Female - Passive
Main Stereo Audio Output	5-pin Phoenix Captive Screw Terminal Unbalanced or Balanced (set via jumpers) Gain: 1.0 Max Signal: $\pm 5V / \pm 30$ mA
Controls	
External	Horizontal Position Control Input Selector
Internal	10 Dip Switches Audio Output Unbalanced / Balanced (4 jumpers)
Dimensions	
Size (including junction box)	4.5" H x 8.2" W x 3.6" D / 11.4cm x 20.8cm x 9.2cm
Product Weight	2 lbs. / 0.9 Kg
Shipping Weight	4 lbs. / 2 Kg
Power	
Power Supply	IN9212 Power Supply, +5V $\pm 12V$ terminated with IN9337 7-Pin Phoenix Connector
Power Connector	7-Pin Phoenix Captive Screw Terminal
Optional Power Equipment	IN8500-4: 4-Conductor, 18 gauge, power cable
Regulatory Compliance	
Safety	UL 1950, 3 rd Ed.; CE: EN60950-92; CAN/CSA-22.2 No. 950 3 rd Ed.
EMI	FCC class A; CE: EN50081-1, EN55022, EN50082-1

Parts Included

- (1) **IN2112B** or **IN2112W** Installation Interface
- (1) **IN9212**: Power Supply, +5V \pm 12V terminated with IN9337 7-Pin Phoenix Connector
- (1) **IN9165**: 4-Gang Junction Box, 3.5" deep
- (1) **IN9155**: 3/4" Romex Connector, Cable Strain Relief
- (1) Operation Manual

Required Accessories (ordered separately)

Input & Local Monitor Output Adapter and Extension Cables

VGA: **IN8000 Series** 15-Pin HD Male to 15-Pin HD Female, Various Lengths from 3' to 100'

Other Computers: See list on page 2

Optional Accessories

Audio Input Cables

IN9106: 3.5mm Stereo Mini Male to 3.5mm Stereo Mini Male, 6' long

IN9107: (1) 3.5mm Stereo Mini Male to (2) RCA Male, 6' long

Output Cables

IN7000-5 Series RGBHV Cable: Standard 5 - BNC Cable available in a variety of lengths from 6' to 250'

IN7100-5 Series RGBHV Cable: High Resolution 5 - BNC Cable, available in lengths from 6' to 250'

IN7200-5 Series RGBHV Cable: Ultra High Resolution 5 - BNC Cable, available in lengths from 6' to 250'

Mounting Hardware / Tools

IN9154: 3/4" EMT Conduit Coupler, Set-Screw Type - Connects IN9153 / IN9157 to 3/4" Conduit

IN9155: 3/4" Romex Connector, Cable Strain Relief - For IN9153 / IN9157

TROUBLESHOOTING

The display device connected to the IN2112 output has a bad/scrambled image.

Solution 1: Verify that the correct input cable is being used (see list on Page 2).

Solution 2: The display device connected to the output of the interface may not be compatible with the computer output. Standard 640 x 480 VGA runs at 31.5 KHz, but SVGA can be as high as 48 - 58 KHz depending on the vertical refresh rate. PC, MAC, Sun and other high resolution workstations have new ultra high resolution modes such as 1600 x 1200 and 1800 x 1440 and can output a video signal with a horizontal scan rate of over 100 KHz! Many data monitors and data projectors are not compatible with these resolutions and frequencies.

Solution 3: Check the dip switch settings to make sure the unit is putting out a sync format that the display device can use. For most applications the default dip switch settings (see Page 6) will work best. For LCD / DMD displays, you may have to disable the horizontal position control.

Solution 4: The RGBS or RGBHV cable may have a bad sync line. Try running the sync through another cable.

The output image is very dark.

Solution: The horizontal position control may be set off to an extreme position or may be interacting poorly with the horizontal position control on the display device. Follow the horizontal position adjustment procedure listed on Page 7.

The local monitor looks fine but the image on the LCD projector is wavy or has vertical bars in the picture.

Solution 1: LCD / DMD displays usually work best when the sync signal has minimum sync processing. Set the interface dip switches as indicated in the section **OPTIMAL SETTINGS FOR LCD / DMD DISPLAYS** on Page 4. Setting the interface to RGBHV output and disabling the horizontal position control may alleviate this problem.

Solution 2: LCD / DMD displays often have an adjustment called Phase Adjust or Fine Phase Control. This control should be adjusted to provide the best image.

The output image is missing a color.

Solution: Possibly the output RGSB or RGBHV cable is bad. Try switching connections on the output to verify that the bad color's cable is OK (*Example:* If there is no red, try running the green output through the red cable and see if green is displayed or not.)

The output image is too green.

Solution: The dip switches may be set for Sync on Green output and the display device doesn't like that format. Try changing the dip switches to output an RGSB or RGBHV signal.

The horizontal position control is not working.

Solution 1: Check the dip switch settings (Page 8) to see if the horizontal position control has been disabled.

Solution 2: The input signal may be RGSB (sync on green). The horizontal position control does not work with RGSB input signals.

The output image is doubled, with two images displayed side-by-side.

Solution: The display device may not be compatible with the horizontal scan rate of the computer. This problem often occurs when a 31.5 KHz VGA signal is sent into an RGB monitor that is only compatible with signals at 15.75 KHz.

If problems persist, call INLINE Technical Services at (800) 882-7117 or (714) 921-4100 for further assistance. You may also send email to tech@inlineinc.com. or send a fax to (714)921-4160.

WARRANTY

- ◆ INLINE warrants the equipment it manufactures to be free from defects in materials and workmanship.
- ◆ If equipment fails because of such defects and INLINE is notified within two (2) years from the date of shipment, INLINE will, at its option, repair or replace the equipment at its plant, provided that the equipment has not been subjected to mechanical, electrical, or other abuse or modifications.
- ◆ Equipment that fails under conditions other than those covered will be repaired at the current price of parts and labor in effect at the time of repair. Such repairs are warranted for ninety (90) days from the day of re-shipment to the Buyer.
- ◆ **This warranty is in lieu of all other warranties expressed or implied, including without limitation, any implied warranty or merchantability or fitness for any particular purpose, all of which are expressly disclaimed.**

The information in this manual has been carefully checked and is believed to be accurate. However, Inline, Inc. assumes no responsibility for any inaccuracies that may be contained in this manual. In no event will Inline, Inc. be liable for direct, indirect, special, incidental, or consequential damages resulting from any defect or omission in this manual, even if advised of the possibility of such damages. The technical information contained herein regarding IN2112 features and specifications is subject to change without notice.

IBM is a registered trademark of International Business Machines. Apple, MAC, Quadra and Centris, are registered trademarks of Apple Computers, Inc. Iris Indigo is a registered trademark of Silicon Graphics. Sun Sparc Station is a registered trademark of Sun Microsystems, Inc. All other trademarks and registered trademarks are the property of their respective companies.

All Rights Reserved © Copyright 1997

© INLINE, INC. ◆ 22860 SAVI RANCH PARKWAY ◆ YORBA LINDA, CA 92887
(800) 882-7117 ◆ (714) 921-4100 ◆ FAX (714) 921-4160 ◆ www.inlineinc.com